



**SteelStacks Performing Arts Center | Bethlehem, Pennsylvania**

# Reevaluation of the SteelStacks Performing Arts Center

**Bethlehem, Pennsylvania**

THE PENNSYLVANIA STATE UNIVERSITY  
SCHREYER HONORS COLLEGE

DEPARTMENT OF ARCHITECTURAL ENGINEERING

Sarah A Bednarcik  
Spring 2013

A thesis submitted in  
partial requirements for degree in Architectural Engineering  
with honors in Architectural Engineering

Reviewed and approved\* by the following:

Linda Hanagan  
Associate Professor  
Thesis Supervisor

Ali Memari  
Hankin Chair Professor  
Honors Advisor

\*Signatures are on file in the Schreyer Honors College

# SteelStacks Performing Arts Center

*Bethlehem, Pennsylvania*

## General Information:

**Function:** Arts & Cultural Center

**Size:** 67,167 sq. ft.

**Height:** 64 feet, 4 stories

**Construction:** Jan 2010 - Apr 2011

**Project Cost:** \$48 million

**Delivery:** Design-Bid-Build

## Construction:

Coordination between designers and builders important, as plans finished after breaking ground



## Structure:

**Foundation:** Concrete column piers and footings supporting slab-on-grade

**Superstructure:** Composite slab and metal decking supported by beam, girder, and truss system

**Lateral:** Braced frames and precast panels acting as shear walls



**Sarah Bednarcik**  
Structural

## Architecture:

**Façade:** Textured precast concrete panels & a glass curtain wall system

**Emphasis:** Exposed structural steel and large, open atrium spaces

**Spaces:** Creative commons, cinemas on lower floors; café & stage on upper floors

**Challenges:** Historic site requiring material approval

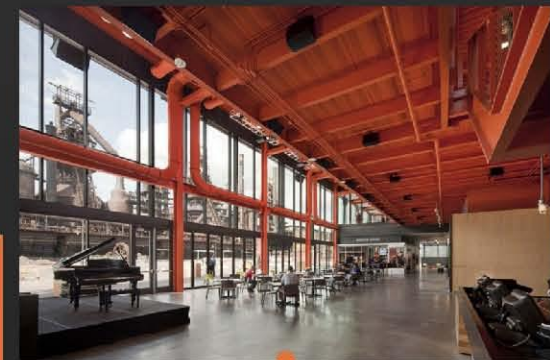

## MEP Systems:

**Mechanical:** VAV with Reheat  
6 Rooftop AHUs at 1650 to 23500 CFM, 1 interior AHU at 5300 CFM  
150 total tons of Direct Expansion cooling

**Lighting:** Façade lit by halides  
Interior includes a mixture of LEDs, fluorescents, incandescents

**Electrical:** 200 kW back-up generator  
Main power 480 V, 3 phase, 4 wire

**Fire protection:** Wet pipe fire suppression system

## Project Team:

**Owner:** ArtsQuest

**Architect:** Spillman Farmer Architects

**Structural:** Barry Isett, Assoc., Inc.

**MEP:** Brinjac Engineering

**CM:** Alvin H. Butz, Inc.

**Civil:** French & Parello

**Acoustic:** Acoustic Dimensions



Images courtesy of respective design professionals.

CPEP Site: <http://www.engr.psu.edu/ae/thesis/portfolios/2012/sab449/index.html>

## Abstract

The purpose of this report is to complete a thorough analysis and redesign of the structural system of the SteelStacks Performing Arts Center (SSPAC) and compare these results to the existing building, evaluating this redesign. The SSPAC is a 64-foot, 4 story, 67,000 square foot arts and cultural center with a steel gravity system and a dual lateral system comprised of braced frames and shear walls.

This report culminates the work of a semester of research and redesign, at the end of which a scenario was created in which the architect wanted to explore cast-in-place concrete as an alternative design option. The new design was decided to include a fully concrete gravity and lateral system. Additionally, the floor system was evaluated and chosen between different systems, a reinforced one-way slab and beam system and a prestressed system.

The goal of this redesign is to evaluate the benefits of both the existing steel system and a reinforced concrete system through a comparison of the benefits and issues with each. This analysis necessitated considering benefits and disadvantages including the structural benefits to each system, flexibility in design, cost, and construction.

The proposed redesign and change in materials resulted in a need to evaluate the acoustic performances of these spaces. This acoustic breadth considered both floor systems and the impact of these materials on the sound transmission as well as the reverberation time within each space.

Results from this analysis led to the conclusion that concrete benefits the system in terms of the many cantilevers and framing configurations seen throughout the SSPAC, while steel is a continued benefit in other areas if the layout is kept the same. If concrete were to be implemented, the building would benefit from seeing some slight changes to layout and structural design.

Cost and construction were seen as more effective in steel. The considerations on acoustics and architecture resulted in successful adjustments to the concrete structure to create a more effective design. Acoustics in particular, were improved through the use of concrete, as it is naturally a better system for the required sound isolation and reverberation of the spaces in the SSPAC.

## Table of Contents

Abstract .....	i
Acknowledgements.....	viii
Chapter 1: Building Introduction .....	1
1.1 Existing Structural System.....	3
1.1.2 Structural System Overview .....	3
1.1.3 Foundation .....	4
1.1.4 Floor System .....	4
1.1.5 Framing System .....	5
1.1.6 Lateral System .....	6
1.2 Design Codes .....	8
Design Codes: .....	8
Design Guides Used for Design:.....	8
Thesis Codes & Design Guides: .....	8
1.3 Materials .....	9
Concrete .....	9
Steel.....	9
Other .....	9
1.4 Gravity Loads.....	10
1.4.1 Dead and Live Loads .....	10
1.5 Lateral Loads .....	11
1.5.1 Wind.....	11
1.5.2 Seismic.....	14
1.5.3 Comparison of Lateral Forces.....	16
1.6 Problem Statement: .....	17
1.7 Proposed Solution: .....	18
1.7.1 Breadth Study.....	18
1.7.2 MAE Component.....	19
Chapter 2: Structural Depth .....	20
2.1 Gravity Redesign .....	21
2.1.1 Beams & Slabs.....	23
2.1.2 Columns & Gravity Walls.....	28

2.1.3 Foundations.....	30
2.1.4 Design Summary.....	31
2.2 Lateral Redesign .....	33
2.2.1 RAM Input & Confirmations.....	33
2.2.2 Applied Building Loads.....	35
2.2.3 Load paths.....	36
2.2.4 Design Results .....	39
2.3 Comparison.....	40
2.4 MAE Coursework Integration.....	41
Chapter 3: Breadth I: Acoustics.....	42
3.1 Reverberation Time .....	42
3.2 Sound Transmission Criteria.....	45
Conclusions.....	48
Chapter 4: Breadth II: Architecture .....	49
4.1 Creative Commons.....	49
4.2 Blast Furnace Room.....	51
Chapter 5: Conclusion.....	53
References.....	54
Appendix A Structural System Overview.....	55
Site Plan Detail .....	55
Architectural Floor Plans .....	56
Structural Floor Plans .....	58
Lateral System .....	59
Appendix B Existing: Wind Calculations .....	60
Appendix C Existing: Seismic Calculations .....	63
Appendix D Gravity Redesign.....	66
RC System .....	66
Prestressed System:.....	79
Comparison.....	82
Columns & Walls:.....	83
Foundations.....	89
Appendix E RAM Model & Building Properties.....	92
Center of Mass & Center of Rigidity .....	92

Load Transfer.....	93
Torsion.....	95
Appendix F Lateral Redesign.....	96
Applied Building Loads.....	96
Design Results.....	101
Appendix G Breadth – Acoustics.....	106
Reverberation Times.....	106
Sound Transmission Criteria.....	110
Cost Comparison.....	111

## Index of Figures

Figure 1: Interior atrium space, highlighting opening structural plan.....	1
Figure 2: Floor Plan from A2.2.....	2
Figure 3: Third Floor Plan from A2.3.....	2
Figure 4 : Image displaying the separation of spaces through the structural design.....	3
Figure 5 : Section of foundation to precast panel connection from S1.0. ....	4
Figure 6 : Typical composite slab section for building from S2.8.....	4
Figure 7 : Third floor representative framing system truss from S2.6. ....	5
Figure 8: Second floor framing plan, representative bay of a typical frame, from S2.0.....	6
Figure 9 : Cross section of the roofing system.....	6
Figure 10 : Floor plan highlighting shear walls and braced frames, contributing to the lateral system. ....	7
Figure 11 : Building dimensions simplified for wind load calculations following Method 2. ....	11
Figure 12: Summary of East-West wind pressures in elevation. ....	13
Figure 13: Summary of final forces in East-West direction in elevation.....	13
Figure 14: Summary of forces in the North-South direction in elevation.....	14
Figure 15: Summary of final forces in North-South direction in elevation. ....	14
Figure 16 : Summary of forces due to seismic loads. ....	15
Figure 17: Camera view for 3D images .....	20
Figure 18: 3D view with shear walls in orange, other walls eliminated for visibility. ....	20
Figure 19: Expanded view highlighting focus spans and cantilevers. ....	21
Figure 20: Primary spaces highlighted, mechanical roof bay as example. ....	22
Figure 21: Mechanical roof.....	23
Figure 22: Reinforced concrete ne-way slab and beam system results.....	24
Figure 23: Prestressed one-way slab & beam system .....	25
Figure 24: Tendon profile for prestressed slab .....	26
Figure 25: Tendon profile for prestressed beam .....	26
Figure 26: Highlighted columns designed by hand, walls eliminated .....	28
Figure 27: Resulting 24"x24" columns, walls eliminated.....	29
Figure 28: Typical gravity wall design .....	30
Figure 29: Lateral walls, highlighted .....	33
Figure 30: East-west load path.....	37
Figure 31: Lateral system details to be considered further .....	38
Figure 32: Shear wall highlighted.....	38

Figure 33: Typical shear wall detail.....	39
Figure 34: Spaces considered in acoustic analysis highlighted .....	42
Figure 35: Second & third floor overlay .....	45
Figure 36: Section showing STC values .....	45
Figure 37: Floor composition options.....	46
Figure 38: Comparison for Creative Commons and Musikfest Cafe.....	47
Figure 39: Comparison for Creative Commons and Blast Furnace Room .....	47
Figure 40: Camera view for Creative Commons .....	49
Figure 41: Existing Creative Commons space.....	50
Figure 42: Redesigned Creative Commons space.....	50
Figure 43: Camera view for Blast Furnace Room .....	51
Figure 44: Existing Blast Furnace Room space .....	52
Figure 45: Redesigned Blast Furnace Room space.....	52



## Index of Tables

Table 1: Table of Superimposed dead loads .....	10
Table 2: Table of live loads used on the structural plans and in this report.....	10
Table 3: Summary of wind pressure calculations in the East-West direction.....	12
Table 4: Summary of overturning moment and base shear calculations in the East-West direction .....	12
Table 5: Summary of wind pressures in the North-South direction.....	13
Table 6: Summary of overturning moment and base shear calculations in the North-South direction. ....	13
Table 7: Hand calculations for wind loads per floor.....	14
Table 8: Table of seismic load variables and values.....	14
Table 9: Summary of calculations for seismic load design.....	15
Table 10: Comparison of lateral forces.....	16
Table 11: Comparison of story shears.....	16
Table 12: Gravity redesign results .....	23
Table 13: Prestressed gravity design results .....	26
Table 14: System comparison.....	27
Table 15: Gravity redesign results .....	29
Table 16: Foundation design results, by hand.....	30
Table 17: Torsional amplification factors applied .....	34
Table 18: Wind loading results .....	35
Table 19: Drift & displacement results, wind loading .....	35
Table 20: Seismic load results .....	36
Table 21: Drift & displacement results, seismic loading .....	36
Table 22: Reverberation times for the Blast Furnace Room.....	43
Table 23: Reverberation times for Theater 1 .....	43
Table 24: Reverberation times for Theater 2 .....	44
Table 25: Reverberation times for the Creative Commons.....	44
Table 26: Cost comparison of floor systems.....	48

## Acknowledgements

I am very grateful to Barry Isett Associates and ArtsQuest for providing me with the opportunity to use the SteelStacks Performing Arts Center. An especial thank you goes to Ross Sotak, who gave valuable insight and advice throughout this process.

The AE faculty also deserves special thanks, for their passion and help throughout my time at Penn State. This especially includes:

Dr. Hanagan

Dr. Vigeant

Kevin Parfitt & Robert Holland

My fellow classmates, who spent hours working and encouraging me and helping me, include:

Jon Fisher	Matthew Neal
Andrew Voorhees	Cheuk Tsang
Jon Gallis	Rose Paddison
Sean Felton	Allie Pladson
Dan Bodde	

My family has been a never-ending support system, and through their encouragement and support, I have come through better reminded of why I enjoy what I study.

Most importantly, I thank Christ Jesus, for giving me a reason to enjoy my work and purpose for it all.

## Chapter 1: Building Introduction

The SSPAC is a new arts and cultural center designed to fit into the historic yet modern atmosphere of its location on the site of the previous Bethlehem Steel Corporation and situated near downtown Bethlehem. The owner is committed to uniting the community through the transformation of this brownfield into a revitalized historic site with LEED Silver status for the SSPAC is in progress. This has been achieved architecturally and structurally through the raw aesthetics of the steel and concrete structure, sitting amongst the skeletons of Bethlehem Steel as shown in Figure 1.

Exposed structural steel and large atrium spaces in the SSPAC imitate the existing warehouses and steel mill buildings for integration into the site. Yet in contrast, the SSPAC has an outlook on the community, with a large glass curtain wall system opening the interior atriums to the surrounding site. These atriums also look introspectively, uniting the various floors together as part of the mission to unite the community. These open spaces vary in size, location, and specific use, and yet all deliver similar results.

The first floor consists of public spaces, such as a commons area open to above, and cinema spaces. The second floor is similar, with a mezzanine open to the common area on the first floor, as seen in the second floor plan in Figure 2. The third and fourth floors consist of a stage and small restaurant connecting the two floors via an atrium, and a cantilevered terrace adjoining the third floor, as seen in the third floor plan in Figure 3. The balcony portion of the restaurant on the fourth floor overlooks the third floor stage, as seen via outline on the third floor plan. Both the third and fourth floors have back-of-house spaces such as kitchens, offices, storage, and green rooms that service the public spaces. Other architectural floor plans are included in Appendix A.

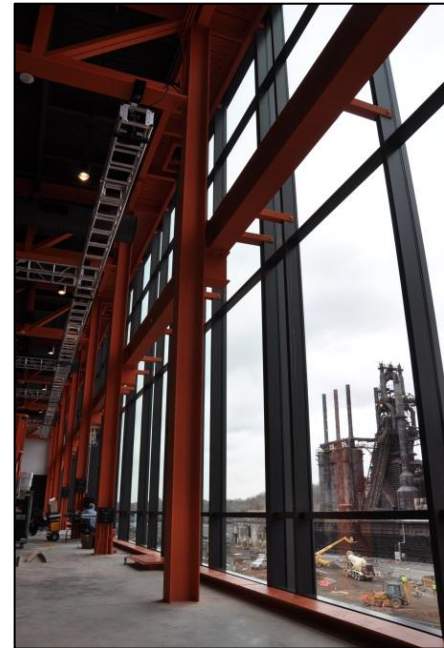

Figure 1: Interior atrium space, highlighting opening structural plan.

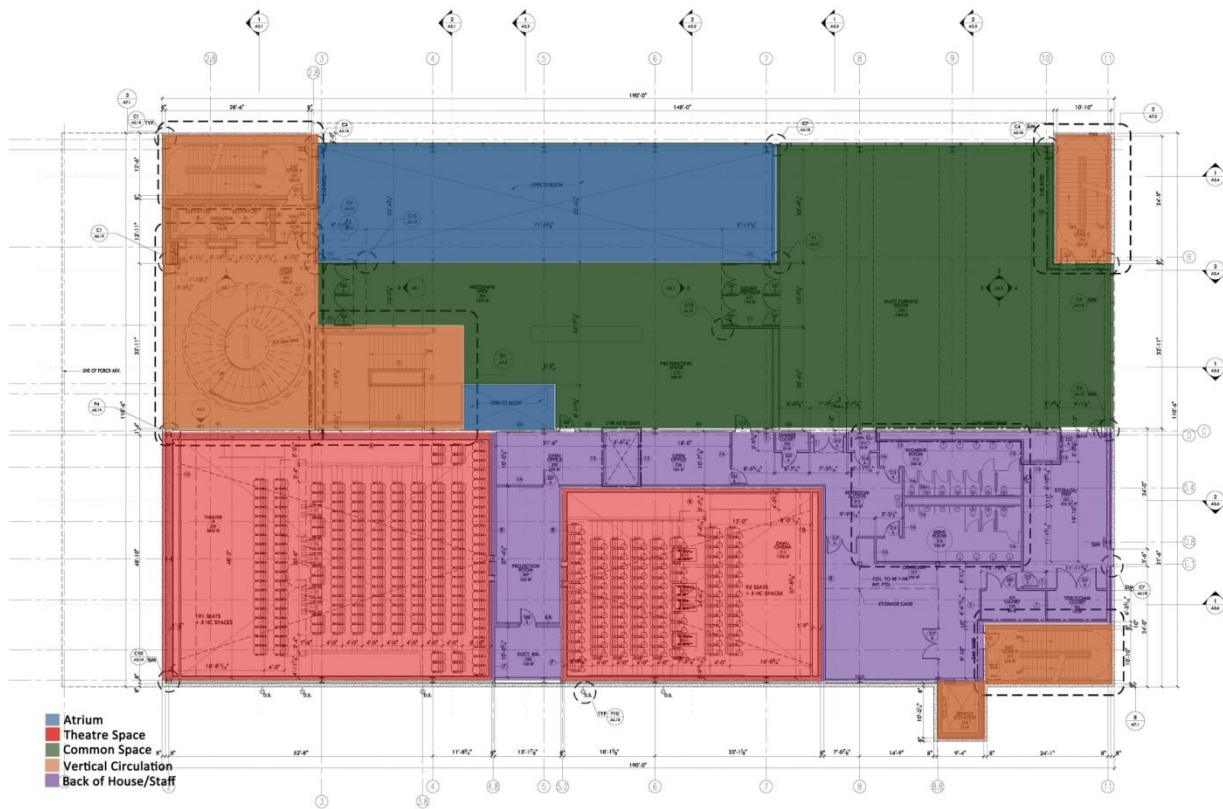

Figure 2: Floor Plan from A2.2

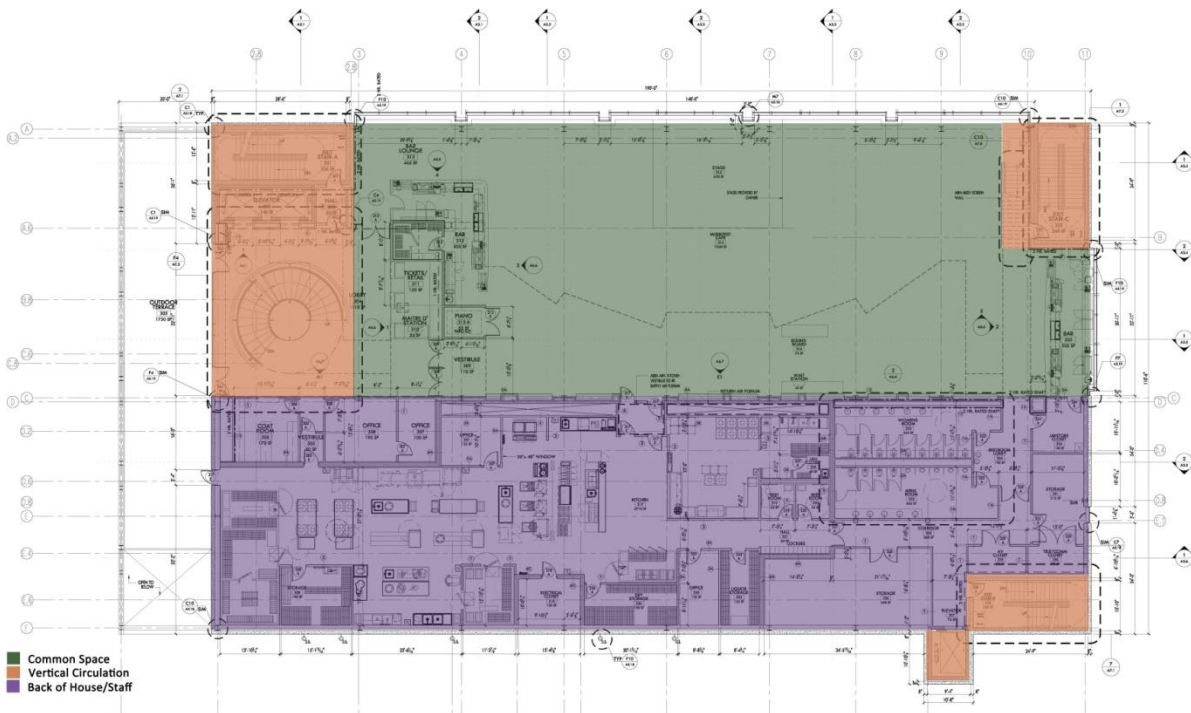
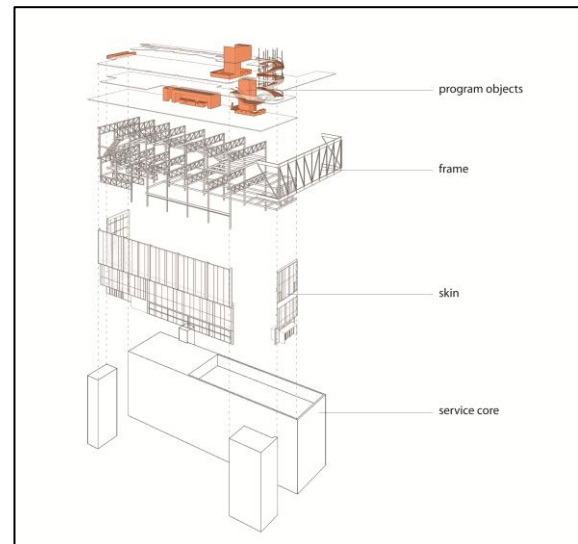

Figure 3: Third Floor Plan from A2.3

This \$48 million project is approximately 67,000 square feet and is four stories above grade, with an integrated steel and concrete panel structural system. With a total building height of 64 feet, each level has a large floor-to-floor height, allowing for more open spaces and larger trusses to span the undersides of each floor system, mirroring the style of trusses found in an original warehouse. The spaces in the SSPAC include creative commons, theatres, a café, stage and performance area, production rooms, offices, and kitchens.

The main features of the façade are precast concrete panels with a textured finish, mimicking the aesthetics of the surrounding buildings, as well as a glass curtain wall system. The curtain wall system includes low E and fritted glazing along the northern facing wall that allows light to enter throughout the atrium common spaces on all floors. This is supported by the steel skeleton, which divides the building structurally into two acoustic portions, keeping vibrations from the north and south halves of the building from transferring, as seen in Figure 4.

While the SSPAC does not have any highlighted features that distinctly call to its LEED Silver certification, the integration towards sustainability of building design, use, and construction has been thoroughly developed in the structure and site. The overall building aesthetics and structural system can be attributed partially to sustainability, but also to the historical values that the site brings and the future purpose of the space integrating into these focuses.



**Figure 4 :** Image displaying the separation of spaces through the structural design.

Images courtesy of Barry Isett, Inc. & Assoc.

## 1.1 Existing Structural System

This section provides a brief overview of the SSPAC in terms of the structural system, design codes, and materials, detailing the structural elements and factors associated with the structure's design and performance.

### 1.1.2 Structural System Overview

The structure of the SteelStacks Performing Arts Center consists of steel framing on a foundation of footings and column piers. Precast concrete panels and braced frames make up the lateral framing. The second, third, and fourth floors consist of normal weight concrete on metal decking, supported by a beam and truss system. The roof consists of an acoustical decking and slab system.

### 1.1.3 Foundation

French & Parrello Associates conducted field research on May 20, 2009, collecting the plan and topographic information shown on the civil drawings. The site of the SSPAC had an existing building, to be fully removed before start of construction. This demolition included the removal of the foundation and slab on the west side of the site. The location of an underground tunnel directly under the existing building was also taken into consideration when designing the foundation system for the SSPAC. The SSPAC is built above the original building portion that was demolished. A plan of this is included in Appendix A.

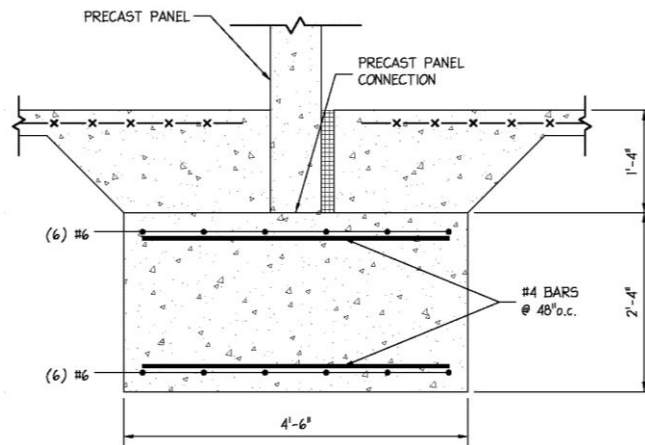

Figure 5 : Section of foundation to precast panel connection from S1.0.

Following the survey findings, provisions were supplied for instances of sink holes, accelerated erosion, and sediment pollution. The soil bearing pressure has been recommended on the subsequent plans as a minimum of 3000 psf, with precautions during construction required due to these results.

The foundation was then determined to be a system of column piers and footings supporting a slab-on-grade. The column footings varying in size from 3'0" x 3'0" to 20'0" x 20'0" and vary in depth from 1'0" to 4'2". The variation in dimensions and depths of the column footings is due to the building design as well as the soil and other existing conditions that lead to settlement and strength issues. The foundations allow for a transfer of gravity loads into the soil, as seen in Figure 5, through connection with the first floor system and precast concrete panels.

### 1.1.4 Floor System

The first floor system is directly supported by the foundation of the building, with a 4" reinforced concrete slab sitting on top of a sub-floor composed of 4-6 inches of compacted gravel or crushed stone. The second and fourth floors consist of a 5" concrete slab on 2" x 20 GA galvanized composite metal decking. This decking is supported by composite beams for smaller spans for the back-of-house spaces, while exposed trusses support this floor system for larger, public spaces. Uniquely, the third floor is comprised of an 8" concrete slab on 2" x 16GA galvanized composite metal decking. This difference in slab thickness is due to acoustics of the

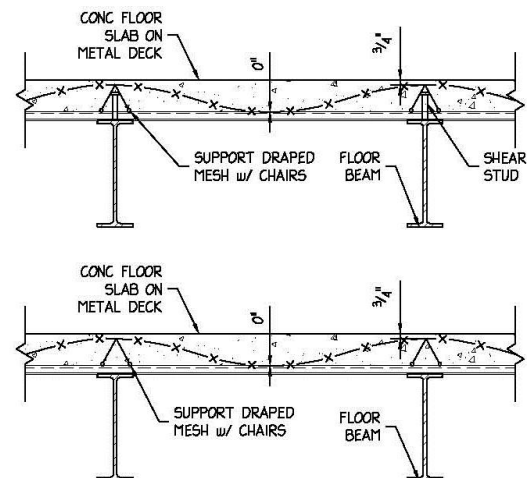

TYP. COMPOSITE SLAB CONSTRUCTION

SCALE:  $\frac{3}{4}" = 1'-0"$

Figure 6 : Typical composite slab section for building from S2.8

spaces, requiring more vibration and sound isolation around the stage for band performances. Therefore it is a galvanized epicore 20GA roof deck, an acoustical decking and slab system.

Metal decking is connected to beams and girders with metal studs where appropriate. Decking is based on products from United Steel Deck, Inc. Depending on location, decking varies between roof decking, composite, and non-composite decking, but all decking is welded to supports and has a minimum of a 3-span condition. A section of the composite slab for this building can be seen in Figure 6.

### 1.1.5 Framing System

Supporting the floor systems are series of beams, girders, and trusses. Floor beams are spaced at a maximum of 7'6". The beams are also generally continuously braced, with  $\frac{3}{4}$ " x 4" long shear studs spaced along all beams connecting to the composite slabs. Trusses support larger spans in atrium and public spaces, while composite beams support the smaller spans for spaces such as hallways, meeting rooms, and back-of-house spaces.

Generally, the second floor consists of W12x26s for the mezzanine area and W24x76s for the Blast Furnace Room. Beams for the third floor are W12x16s, spanning between 18'6" to 22'2". These beams are then supported by trusses, representative ones shown in Figure 7.

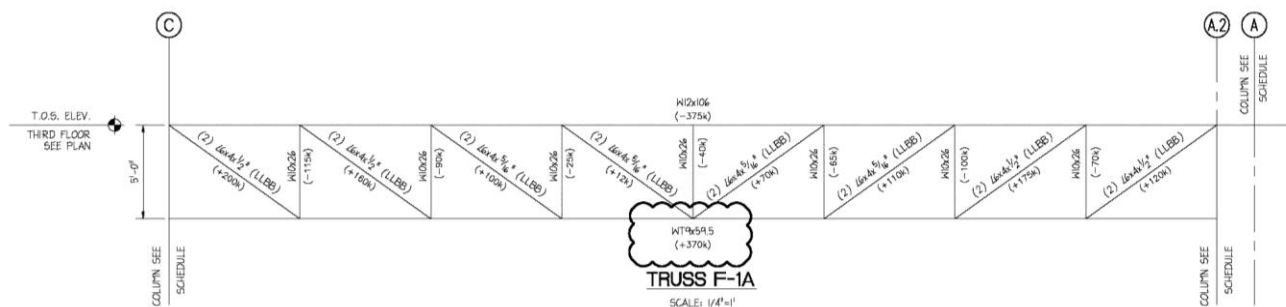

Figure 7 : Third floor representative framing system truss from S2.6.

Framing on the fourth floor is more irregular, as explained previously and included in Appendix A, due to a large portion of the space open to the third floor, and approximately 25% of the square area excluded due to the mechanical roof. Yet even with the irregular framing plan, the beams are mostly W12x14 for public space, restroom facilities, and storage spaces and W18x35s supporting the green rooms and offices. The mechanical roof has typical framing members of W27x84s supported by Truss R-2, in a similar layout to that of Truss F-1A in Figure 7.

As explained above, this building has inconsistent framing from floor to floor, due to the variability in the space purposes. While no one framing plan is consistent throughout the building, a representative bay is highlighted in Figure 8. Structural framing plans for referenced floors are in Appendix A. This bay is taken from the second floor, which uses the most consistent flooring and framing seen in other portions of the building and on the fourth floor and roofing plans.

The roof framing plan is similar to that of the third floor, both in layout of beams and supporting trusses. Typical beam members are W12x26s, with larger spans along the eastern side of the building leading to larger members.

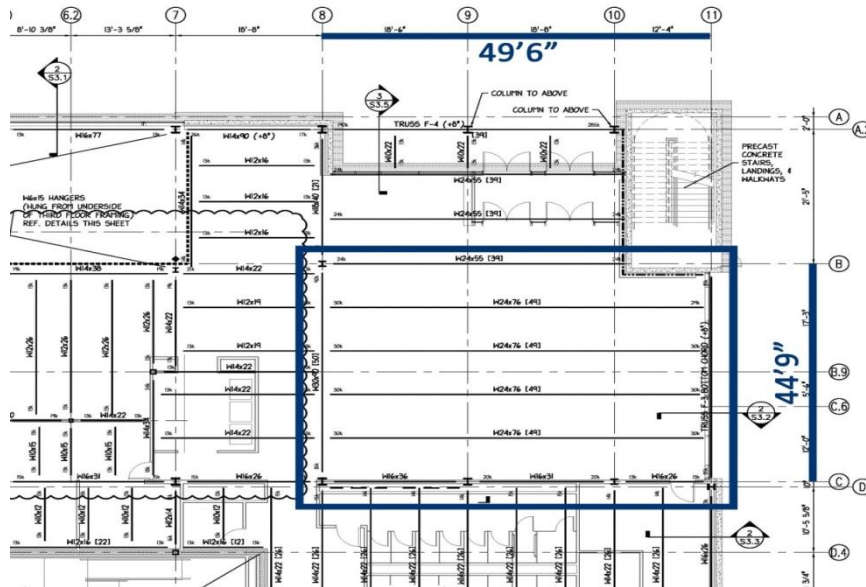

Figure 8: Second floor framing plan, representative bay of a typical frame, from S2.0

Above all of the roof framing is the same finish, a fabric-reinforced Thermoplastic Polyolefin (TPO). This involves a light colored fully adhered roofing membrane on lightweight insulated concrete, lending to the LEED Silver status for the SSPAC. See Figure 9 for a cross section of the roof framing and system.

Supporting the floor systems is a combination of braced frames, columns, and precast panels. Columns are generally W12s, as the structural engineer focused on not only supporting the structure, but keeping the steel consistent dimensions. HSS columns were also used at varying locations, and varied from HSS4x4s to HSS10x10s.

### 1.1.6 Lateral System

The lateral system of this building varies per direction. In the North-South direction, the lateral system consists of shear walls. These shear walls are comprised of the precast concrete panels found along the exterior of the building, and highlighted in orange in Figure 10. These panels are 8" thick normal weight concrete and are anchored with L5x5x5/16" to the structure for deck support and into the foundation as discussed and detailed previously.

Braced frames along Column Line C in the East-West direction consist of the other component to the lateral framing system. These braced frames are highlighted in

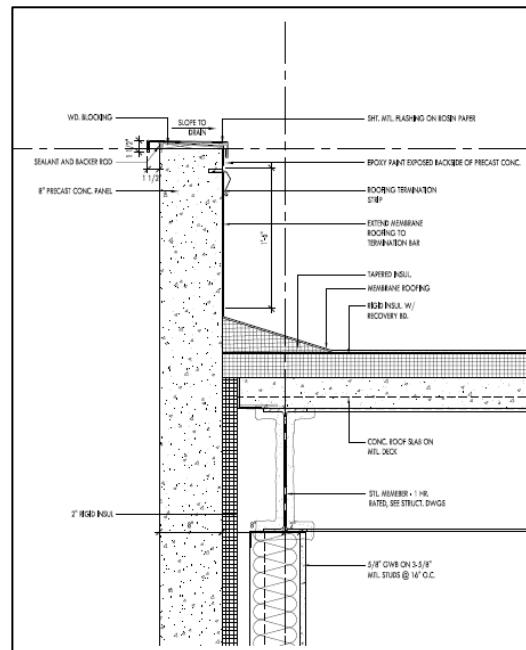

Figure 9 : Cross section of the roofing system.



blue in Figure 10 and are comprised of W10x33s for diagonal members and W16x36s for horizontal members. An elevation of these lateral systems is included in Appendix A.

The lateral loads on the structure first impact the exterior components and shear walls. Where braced frames are concerned, this load travels through the horizontal members into the diagonal and vertical members. These loads all then continue into the foundation.

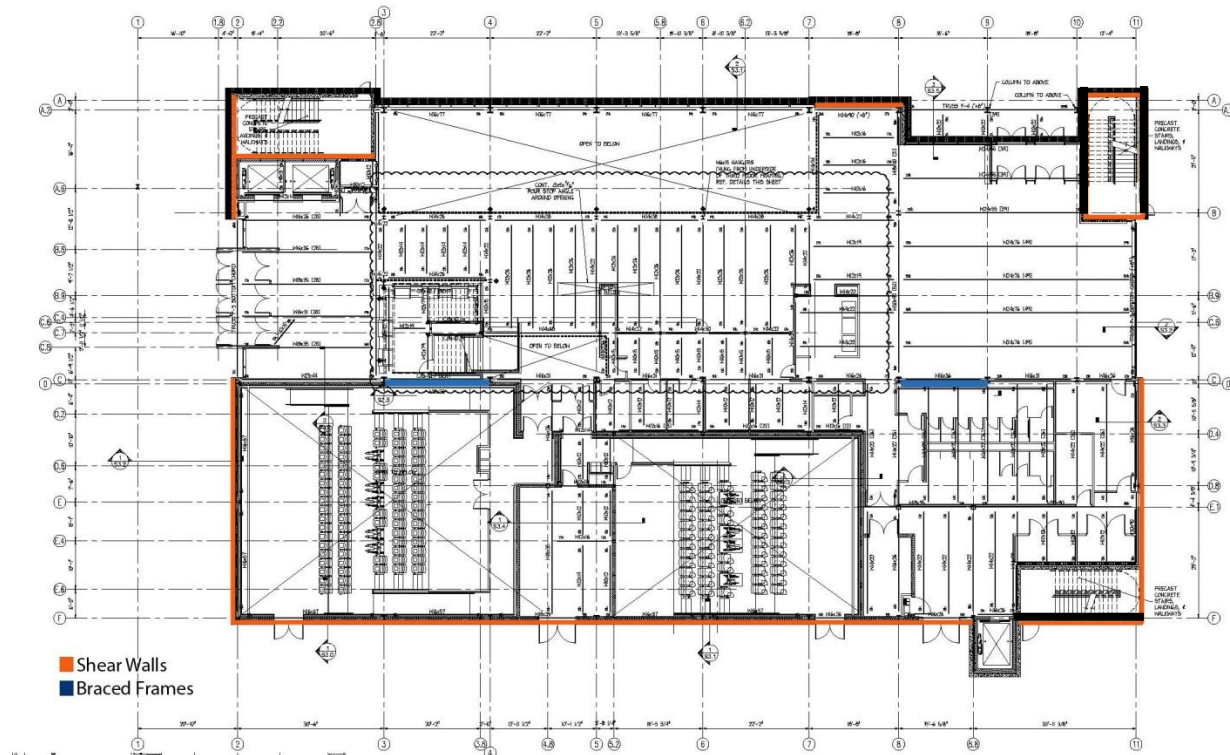

Figure 10 : Floor plan highlighting shear walls and braced frames, contributing to the lateral system.

## 1.2 Design Codes

This section lists codes and design guides followed for the structural designs for the SSPAC, as well as applicable codes and design guides used throughout this report. Most recent code editions have been used for this report, and these differences should be noted below.

### Design Codes:

- 2006 International Building Code (IBC 2006) with Local Amendments
- American Concrete Institute (ACI) 318-08, Specifications for Structural Concrete for Buildings
- American Concrete Institute (ACI) 530-2005, Building Code Requirements for Concrete Masonry Structures
- American Society of Civil Engineers (ASCE) 7-05, Minimum Design Loads for Buildings and Other Structures
- American Society of Civil Engineers (ASCE) 6-05, Specifications for Masonry Structures

### Design Guides Used for Design:

- Steel Deck Institute (SDI), Design Manual for Floor Decks and Roof Decks
- Steel Deck Institute (SDI), Specifications for Composite Steel Floor Deck
- National Concrete Masonry Association (NCMA), Specifications for the Design and Construction of Load-Bearing Concrete Masonry

### Thesis Codes & Design Guides:

- American Society of Civil Engineers (ASCE) 7-05, Minimum Design Loads for Buildings and Other Structures
- American Concrete Institute (ACI) 318-11, Specifications for Structural Concrete for Buildings
- American Institute of Steel Construction (AISC), Steel Construction Manual, 14<sup>th</sup> Edition
- Vulcraft Steel Decking Catalog, 2008

### 1.3 Materials

The following materials and their corresponding stress and strength properties have been listed below, as those used both in the existing building and for calculations for this report.

#### Concrete

Concrete slabs	$f'c = 4000$ psi @28 days
Reinforcing Bars Plain-Steel	$f'c = 3000$ psi
Other Concrete	$f_y = 60$ ksi

#### Steel

W-Shapes	$F_y = 50$ ksi
Channels, Angles	$F_y = 36$ ksi
Plate and Bar	$F_y = 36$ ksi
Cold-formed hollow structural sections	$F_y = 46$ ksi
Hot-formed hollow structural sections	$F_y = 46$ ksi
Steel Pipe	$F_y = 36$ ksi

#### Other

Concrete Masonry Units	$f'm = 1900$ psi
Mortar, Type M or S	$f'm = 2500$ psi
Grout	$f'm = 3000$ psi
Masonry Assembly	$f'm = 1500$ psi
Reinforcing bars	$F_y = 60$ ksi

\*Material properties are based on American Society for Testing and Materials (ASTM) standard rating.

## 1.4 Gravity Loads

This section details the provided design loads for the SSPAC from the structural plans. Other loads have been derived as appropriate, with minimal differences in values calculated for this report and for initial design. It is noted that not all of these loads are applicable to the preceding comparisons, but have been included as a brief summary of the structural loadings.

### 1.4.1 Dead and Live Loads

**Table 1:** Table of Superimposed dead loads

Dead loads were not given on the structural drawings, and have therefore been assumed based on structural design textbooks. For a summary of the dead load values used in this report, see Table 1.

Superimposed Dead Loads	
Description	Load (psf)
Concrete Masonry Units (CMU)	91
Prefabricated Concrete Panels (8" thick)	100
Glazed Aluminum Curtain Walls	90
Roofing	30
Framing	7
MEP Allowance	5

Conversely, the structural notes did provide partial live loads. These load values were compared with those found on Table 4-1 in American Society of Civil Engineers (ASCE) 7-05. As live loads on the plans are compiled to more overarching space divisions, other specific loads relevant to the building have been included for comparison in Table 2. One difference to note is the stage area on the third floor. If considered a stage floor by ASCE7-05, the loading here would be 150 psf. Yet, the structural drawings note all live loads, excluding mechanical, at 100 psf. This could be due to overestimating other spaces, such as theatre spaces, and using an average, yet still conservative, value. Live load reductions were not considered, as the SSPAC is considered under the "Special Occupancy" category, as a public assembly space, as per ASCE 7 -05 Chapter 4.8.4, and disallows the use of reduction factors on any live loads.

**Table 2:** Table of live loads used on the structural plans and in this report

\*Dashes designate values not provided in the structural drawings.

Live Loads*		
Space	Structural Plan Load (psf)	Report Load (psf)
Live Load	100	100
Corridor	100	100
Corridor, above 1st floor	---	80
Stairway	100	100
Mechanical Room/Light Manufacturing	125	125
Roof	30	20
Lobby	---	100
Theatre, stationary seating	---	60
Stage Floor	---	150
Restaurant/dining space	---	100
Balcony	---	100

## 1.5 Lateral Loads

This section details the lateral loads that impact the structural system of the SSPAC, so that a more thorough understanding of the SSPAC would be obtained. For this report, both wind loads and seismic loads were calculated and applied to the model produced in RAM Structural System. Hand calculations for these load considerations can be found in Appendix B (Wind) and Appendix C (Seismic).

### 1.5.1 Wind

Wind loads were calculated using ASCE 7-05 Chapter 6, where Method 2 for Main Wind-Force Resisting Systems was applied to the structure. Due to the fact that the building is a low-rise building, with generally simple dimensions, this method was deemed appropriate. With this process of calculating the simplified design wind pressures, the dimensions of the building were simplified to the dimensions seen in Figure 11. The mechanical roof, realistically slightly lower than the rest of the roof, is surrounded by a parapet. With this scenario, the mechanical roof was considered to be at the same height at the adjoining roof for simplification and use of Method 2. Thus, the overall roof height is at an elevation of 64'0" relative to the ground.

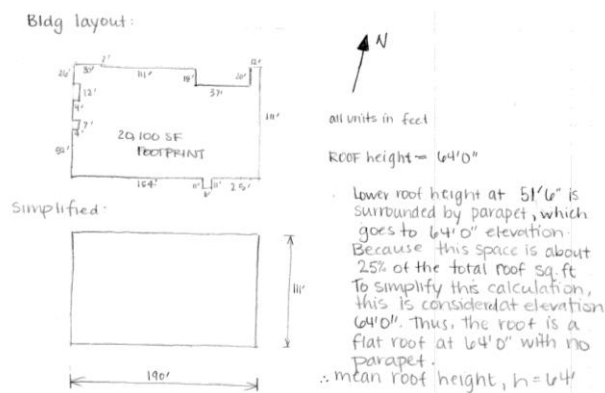

Figure 11 : Building dimensions simplified for wind load calculations following Method 2.

Calculations considered the wind coming along the East-West and North-South directions. The system is a rigid system, estimated by following the preferred method in the commentary of ASCE 7-05 Section C6. With this in mind, the gust effect factor was found to be .873 in the East-West direction and .853 in the North-South direction, which is slightly above the allowable minimum of  $G=.85$  for rigid systems. Another portion of the calculations to highlight is the external pressure coefficient,  $C_p$ . This value varies per direction, as divided in Figure 6-6 of ASCE Chapter 6. A spreadsheet was formed for ease and accuracy of values for wind, and can be found in Appendix 2, along with the preceding hand calculations previously mentioned.

A summary of the wind pressures and variables going into these pressures in each direction are displayed below, in the tables and figures following. These results have been summarized for the East-West direction in Table 3, Table 4, Figure 12, and Figure 13 and highlight the base shear and overturning moment due to these wind pressures. Table 5, Table 6, Figure 14, and Figure 15 summarize similar results and drawings for the North-South direction. Table 7 gives a comparison of a summary of the loadings from each direction.

The structural drawings included input values and a total windward pressure. The input variables were compared with hand calculations and confirmed exact in most cases. For example, the maximum total windward pressure from the structural drawings was 38.9 psf, where the maximum value calculated below was 49.8 psf. The reason for these differences is that the value obtained by hand calculations did not include the internal pressures on the windward side, which would decrease the maximum loading seen.

The overall base shear for the East-West direction is 105.5 k, with an overturning moment of 3159 k-ft. These results can be compared with the North-South direction, where the base shear was higher, at 208.8 k, and the overturning moment at 6116 k-ft. When considering these results in relation to each other, and taking into account the building dimensions and direction, the proportion between building dimensions and base shear are fairly similar. Beyond the comparison between directions of the wind loading, these results, when considered in light of the building height and basic structure parameters, are reasonable values.

When finding the lateral loading on each floor due to the wind load, a factor of 1.6 was not applied, as per ASCE 7-05. The factor of 1.6 will be applied later for load combinations.

**Table 3: Summary of wind pressure calculations in the East-West direction**

Wind Pressures East-West Direction									
Type		Location	Distance (ft)	Pressure Variables					Pressure (psf)
				Cp	qz	qh	G	GCpi	
Wall	Windward	Roof	64	0.8	17.63	17.63	0.873	0.18	12.31
		Floor 4	47.5	0.8	16.82	17.63	0.873	0.18	11.75
		Floor 3	35	0.8	14.80	17.63	0.873	0.18	10.33
		Floor 2	17.5	0.8	12.16	17.63	0.873	0.18	8.49
		Ground	0	0.8	10.05	17.63	0.873	0.18	7.02
	Leeward Side	All	All	-0.36	17.63	17.63	0.873	0.18	-5.54
		All	All	-0.7	17.63	17.63	0.873	0.18	-10.77
Roof		0 to h/2	0 to 32	-0.9	17.63	17.63	0.873	0.18	-13.85
		h/2 to h	32 to 64	-0.9	17.63	17.63	0.873	0.18	-13.85
		h to 2h	64 to 128	-0.5	17.63	17.63	0.873	0.18	-7.70
		>2h	>128	-0.3	17.63	17.63	0.873	0.18	-4.62
<b>E-W load</b>								<b>Sum Wall</b>	34.40
								<b>Sum Roof</b>	-40.02

**Table 4: Summary of overturning moment and base shear calculations in the East-West direction**

Overturning Moment/Base Shear East-West Direction									
	Location	Height	Area Below (ft <sup>2</sup> )	Area Above (ft <sup>2</sup> )	Pressure Below (psf)	Pressure Above (psf)	Story Load (k)	Story Shear (k)	Overturning Moment (k-ft)
Windward Wall	Roof	64	971.25	0	17.29	17.85	16.79	16.79	1075
	Floor 4	46.5	638.25	971.25	15.87	17.29	26.93	43.72	1252
	Floor 3	35	971.25	638.25	14.03	15.87	23.76	67.48	832
	Floor 2	17.5	971.25	971.25	12.56	14.03	25.83	93.31	452
	Ground	0	0	971.25	0	12.56	12.20	105.51	0
	Width (ft)	111				<b>Total Base Shear (k):</b>	105.51	<b>Total Overturning</b>	3159

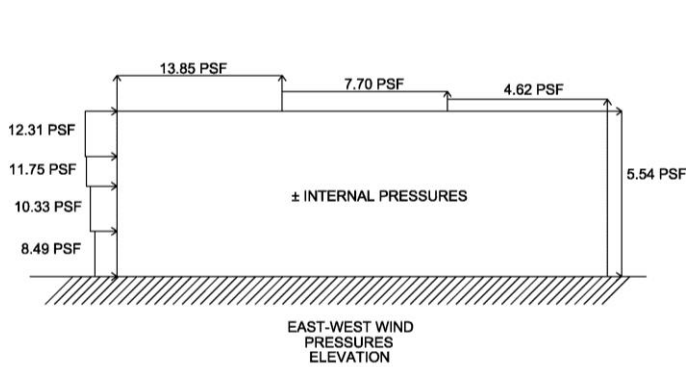

Figure 12: Summary of East-West wind pressures in elevation.

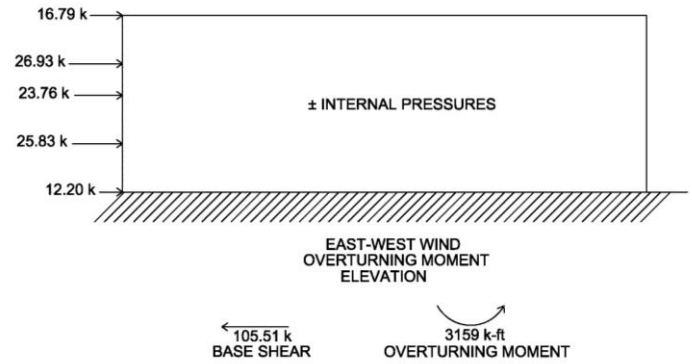

Figure 13: Summary of final forces in East-West direction in elevation.

Table 5: Summary of wind pressures in the North-South direction.

Wind Pressures North-South Direction									
Type	Location	Distance (ft)	Pressure Variables					Pressure (psf)	
			Cp	qz	qh	G	GCpi		
Wall	Windward	Roof	64	0.8	17.63	17.63	0.853	0.18	12.03
		Floor 4	47.5	0.8	16.82	17.63	0.853	0.18	11.48
		Floor 3	35	0.8	14.80	17.63	0.853	0.18	10.10
		Floor 2	17.5	0.8	12.16	17.63	0.853	0.18	8.30
		Ground	0	0.8	11.55	17.63	0.853	0.18	7.88
	Leeward Side	All	All	-0.5	17.63	17.63	0.853	0.18	-7.52
	All	All	-0.7	17.63	17.63	0.853	0.18	-10.53	
Roof	0 to h/2	0 to 32	-1.0	17.63	17.63	0.853	0.18	-15.04	
	h/2 to h	32 to 64	-0.8	17.63	17.63	0.853	0.18	-12.03	
	h to 2h	64 to 128	-0.5	17.63	17.63	0.853	0.18	-7.52	
	>2h	>128	N/A	17.63	17.63	0.853	0.18	N/A	
N-S load							Sum Wall	49.79	
							Sum Roof	-34.59	

Table 6: Summary of overturning moment and base shear calculations in the North-South direction.

Overturning Moment/Base Shear North-South Direction										
	Location	Height	Area Below (ft <sup>2</sup> )	Area Above (ft <sup>2</sup> )	Pressure Below (psf)	Pressure Above (psf)	Story Load (k)	Story Shear (k)	Overturning Moment (k-ft)	
Windward Wall	Roof	64	1662.5	0	19.00	19.55	31.59	31.59	2022	
	Floor 4	46.5	1187.5	1662.5	17.62	19.00	52.51	84.09	2442	
	Floor 3	35	1662.5	1187.5	15.82	17.62	47.22	131.31	1653	
	Floor 2	17.5	1662.5	1662.5	15.40	15.82	51.91	183.22	908	
	Ground	0	0	1662.5	0	15.40	25.61	208.82	0	
	Width (ft)	190						Total Base Shear (k):	208.82	Total Overturning

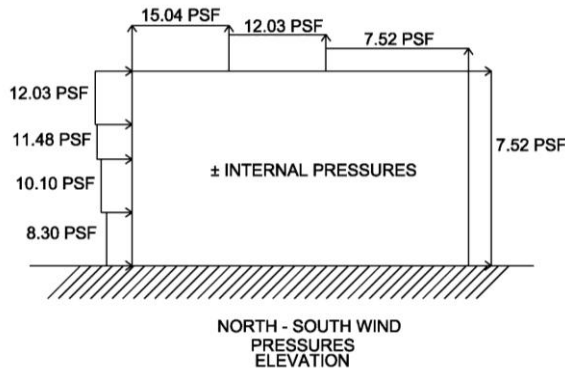

Figure 14: Summary of forces in the North-South direction in elevation.

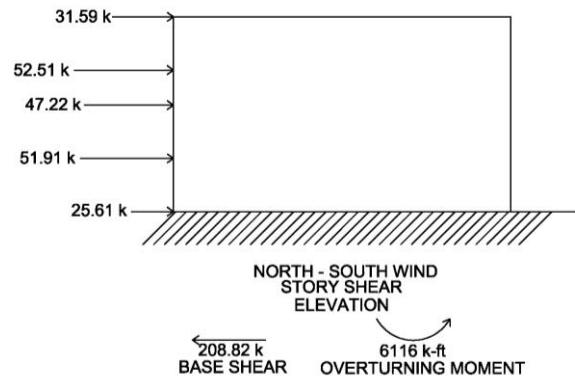

Figure 15: Summary of final forces in North-South direction in elevation.

Table 7: Hand calculations for wind loads per floor.

Wind Loads Per Floor - Summary					
Level	Height	North-South Direction		East-West Direction	
		Total Force (k)	Story Shear (k)	Total Force (k)	Story Shear (k)
Roof	64	31.59	31.59	16.79	16.79
4th	46.5	52.51	84.09	26.93	43.72
3rd	35	47.22	131.31	23.76	67.48
2nd	17.5	51.91	183.22	25.83	93.31

### 1.5.2 Seismic

Seismic calculations followed ASCE 7-05 Chapters 11 and 12, and used the Equivalent Lateral Force Procedure, which is also the method used for the structural plan designs. This procedure included the variables listed in Table 8, some of which were taken from the geo-technical report, while others were calculated. The calculations related to these variables and results are presented in Appendix C. The lateral system for the SSPAC in the East-West direction is a braced-frame and shear wall system, while in the North-South direction, it is a shear wall system comprised of the precast concrete panels seen on the exterior of the building. This needed to be considered for certain variables, such as the response modification coefficient.

Values calculated from this report were compared with those on the structural drawings; all values are exact excluding  $C_s$ . For this value, the structural drawings denote  $C_s=0.138$ , while the calculated value as  $C_s=0.140$  before applying Section 12.8.1-1, which limits this value at

Table 8: Table of seismic load variables and values.

Variable	Value
$S_s$	1.5
$S_1$	0.26
Site Class	D
$S_{ds}$	1.06
$S_{D1}$	0.28
$C_d$	3
$T_s$	0.347
$T_a$	0.6788
$C_u$	1.7
$T$	1.15
$T_L$	6
$C_s$ (limit)	0.042



0.042. This maximum value of  $C_s$  was implemented for seismic calculations.

Once these values were obtained, the base shear needed to be calculated using  $V=C_s*W$ . The structure's weight,  $W$ , was estimated by hand, incorporating all dead weight, slab and framing weight, CMU walls, precast panels, and curtain walls supported by the structure. These calculations can be found in more detail in Appendix 3. This value for the building weight,  $W=11750$  kips, when compared with those calculated by the engineer, were found to be off by less than 10%.

Using the values of  $C_s=0.042$  and the building weight,  $W=11750$  kips, were found, the base shear could then be calculated. The base shear calculated in this report is  $V=493.5$  kips, with an overturning moment of approximately 63925 k-ft, as elaborated on in Table 9 and summarized in Figure 16. Structural drawing S2.8 denotes a base shear value,  $V=506.5$  kips. The calculated base shear is only 2% lower than the value on the structural drawings. This minor difference in base shear can be attributed to the estimating required in hand calculations, while the structural engineer used a structural program to calculate the building weight. These calculations and values can be seen in Appendix C. Accidental torsion impacted the seismic loads, and these values can be found later in this report.

**Table 9:** Summary of calculations for seismic load design.

Seismic Forces							
Level	Story Weight, $w_x$ (lbs)	Story Height, $h_x$ (ft)	$w_x h_x^k$	$C_{vx}$	Story Force (k) $F_x=C_{vx}*V$	Story Shear (k)	Overturning Moment (k-ft)
Roof	2731120.0	64	689,541,085	0.407	200.8	200.8	12850
Mech Roof	35934	51.5	6,795,309	0.004	2.0	202.8	10442
Floor 4	2598740.0	47.5	441,331,912	0.260	128.5	331.3	15735
Floor 3	4047240.0	35	457,898,750	0.270	133.3	464.6	16261
Floor 2	2206440.0	17.5	99,296,222	0.059	28.9	493.5	8637
Ground	N/A	0	N/A	N/A	N/A	N/A	N/A
$C_s$	0.042				Base Shear [ $V=C_s*W$ ] (k)		493.5
$W(k)$	11750				Total Overturning Moment (k-ft)		63925

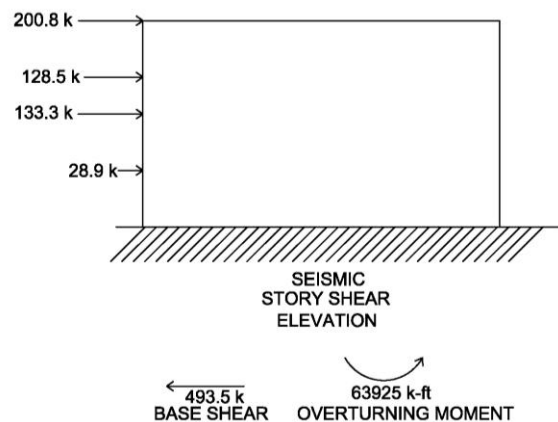

**Figure 16 :** Summary of forces due to seismic loads.

### 1.5.3 Comparison of Lateral Forces

When applying loads to the building, it was necessary to establish whether wind or seismic controlled. Comparisons of the factored wind and seismic loads follow in Table 10 and Table 11. This comparison concluded that seismic loads controlled for base shear and loading on the upper individual floors, while Wind in the North-South direction controlled the overturning-moment and level 2. This can be explained by the seismic load correlation with height and weight of controlling lateral components.

In designing the structural components, the base shear and overturning moment will be important for the design of columns and shear walls. Story shears will be important for designing braces and the loads within them. The distribution of loads per member and confirmation of designed structural components will be discussed in more detail in the Lateral System Analysis section of this report.

**Table 10: Comparison of lateral forces**

Comparison of Lateral Forces			
	Wind, North-South	Wind, East-West	Seismic
Base Shear (k)	208.8	105.5	<b>493.5</b>
Overturning Moment (k-ft)	<b>6115.7</b>	3158.5	63925.2

**Table 11: Comparison of story shears**

Comparison of Story Shears (k)			
Level	Wind, North-South	Wind, East-West	Seismic
Roof	31.6	16.8	<b>200.8</b>
Mech Roof	Negligible	Negligible	<b>202.8</b>
Floor 4	84.1	43.72	<b>331.3</b>
Floor 3	131.31	67.48	<b>464.6</b>
Floor 2	183.22	93.31	<b>493.5</b>
Ground	N/A	N/A	N/A

## 1.6 Problem Statement:

The SteelStacks Performing Arts Center is designed as a steel gravity system with braced frames acting as the lateral system. This is done effectively in the design by variations in floor plans, bays, structural components to result in a framing consists of a composite decking and steel system. The lateral system is designed as a dual system of shear walls and braced frames for the lateral structural system.

A scenario has been created in which the architect would like to explore an alternative option, and the building is required to be built in reinforced concrete. Through the observations made in Technical Report II, this is a viable system redesign for comparison to the existing system. Other alternatives, such as a precast plank floor system, have been disqualified due the inconsistency in bay layouts.

The goal of this redesign is to evaluate the benefits of both the existing system and a reinforced concrete system in a comparison of variables such as structural performance, cost, efficiency, aesthetics, and acoustic performance. With a concrete system in place, braced frames will no longer be a viable lateral system option, and therefore, shear walls will be reconfigured and replace braced frames. The gravity system will be evaluated and redesigned, with larger bays being considered for prestressing.

Therefore, a structural system will be designed with the existing gravity system and lateral system being converted to a reinforced concrete system. One ramification that will need to be considered is concerning floor to floor height, and this will be evaluated as part of the redesign. This redesign will impact the aesthetics, and the redesign will be evaluated for architecture and compared to the existing interior spaces. As the gravity system is being redesigned into concrete, these will also be considered a point of evaluation due to the weight impacts on the lateral system. With upper floors being heavier due to acoustic issues, these will be redesigned with acoustics as a consideration. All of this must be achieved while considering impact on the architectural and acoustical qualities of the structure.

## 1.7 Proposed Solution:

The redesign of the existing lateral and gravity systems will begin with the consideration of the new shear wall layout along the east-west axis. The new lateral system will be an entirely shear wall system, which will be compared to the existing system for design, construction, and cost while maintaining quality in architecture and acoustics.

The gravity system will then be designed in consideration of cost and weight. Currently, the system is designed for consistent size members for aesthetics, as ceilings are exposed. This redesign will consider the impact of a reinforced concrete system that mainstreams bay layouts on cost of materials and construction. This will influence the architecture and aesthetics of the building, and this impact will be considered and is detailed below in the Breadth section. The structural framing members will be designed using ACI 318-11.

Floor diaphragms will be redesigned while maintaining the necessary floor-to-floor dimensions currently in use, with acoustics and sound isolation being taken into consideration, as acoustics were a controlling factor in creating the existing design. Sound isolation issues will be considered for the mentioned floor and space design. Acoustics will be analyzed for Sound Transmission Contours related to each highlighted space, which will then be utilized for deciding on the most viable floor and space options. The ramifications of the new diaphragm design on the acoustic performance of the spaces are detailed in the Breadth section below.

### 1.7.1 Breadth Study

Redesign of the SSPAC for the above mentioned limitations will have a direct impact on various other aspects of the building design, as previously stated. These influences include architectural design, acoustics of each of the altered spaces, construction, and mechanical location and vibration issues. The breadths being considered for this proposal are acoustics and architecture and are elaborated below.

#### *Acoustics:*

Eliminating braced frames and reconfiguring the framing system for a reinforced concrete system will directly impact the acoustics of the building spaces. Interior walls will need to be reevaluated, and acoustic paneling and materials will be adjusted according to calculation results, to maximize noise isolation. By changing the framing plan arrangement, a primary influence would be on the acoustical performance of each of the spaces where the floor diaphragms are designed for sound isolation. One such space that will be impacted is the third floor Musikfest Café and Stage area. A heavier floor system allows for better sound isolation between floors. By altering the floor system, the chosen design might no longer provide a satisfactory acoustic design. Therefore, the floor diaphragms will be analyzed for effectiveness as sound barriers. To analyze the acoustic performances of the space in each option, Reverberation Time values will be decided per room, based on wall and floor material. Existing and

alternatives options will be compared, to conclude on the most viable option according to acoustic performance for the spaces.

### **Architecture:**

By changing the bay layouts and exterior wall system, architectural features will be impacted. By designing shear walls and changing the system to concrete, the interior spaces will be greatly altered, and this fact will need to be considered. The existing architecture also includes exposed ceilings with consistent beam, girder, and truss member sizes for a streamlined look. The proposed redesign continues to include constant sizes, but the use of a different material will impact the aesthetics. The impacts of these system alterations will be visually considered through the use of a Revit model, giving the ability to compare the existing with the new design more exhaustively. A final architectural view will be provided to display the impacts of the design.

### **1.7.2 MAE Component**

As a requirement for the MAE program, the coursework from multiple MAE classes will be incorporated into the completion of this thesis. For completion of the depth, a structural building model will be built in RAM Structural System. This follows the material learned in AE 530, *Computer Modeling of Building Structures*. Use of a detailed structural model will aid in the analysis of building and member loads. Concepts implemented include panel zones, and rigid diaphragm constraints. With the further details of the structural system redesign, material from CE 543, *Prestressed Concrete Behavior and Design*, will also be applied the investigation of the gravity system design. Larger bays will be evaluated for the benefits of designing these bays for prestressing, and will be detailed for the appropriate design results.

## Chapter 2: Structural Depth

The SSPAC is a braced steel frame system with precast concrete panels acting as shear walls. As a building with irregular bays, big curtain wall expanses, and heavy live loads, a steel system is a very effective option that allows for the structural components being designed to match the existing layout.

A fully concrete building can also be designed effectively from these same issues. The use of concrete lends easily to varying bay configurations, and is beneficial in areas of heavier loadings. Other benefits in a concrete redesign are in the areas of large cantilevers and atrium spaces. Concrete is known to be an effective solution for cantilevers where back spans are included, and is therefore a

competitive option. Due to the large floor to floor height already in place because of the deep trusses used to support the large live loads and longer spans, ranging from 4'0" to 7'0" in depth, the use of concrete beams in these locations is an excellent area to explore in redesign. The lateral system exists as a dual system, comprised of shear walls and braced frames. Concrete fits into this framing scheme seamlessly, as shear walls can then act more integrally with the gravity system. Additionally, the construction equipment for the concrete gravity system will already be on site, so a cast-in-place, versus continuing with precast shear walls, is a more logical decision. The existing system is controlled by seismic loads, and with the conversion to an entirely concrete system, seismic loads are expected to continue controlling.

Therefore, the building redesign consists of a one-way slab and beam system with columns and gravity walls. This design is integrated with the lateral system, a set of shear walls in both directions, as seen in Figure 18 (gravity walls are hidden for ease of view), as viewed from the camera view in Figure 17.

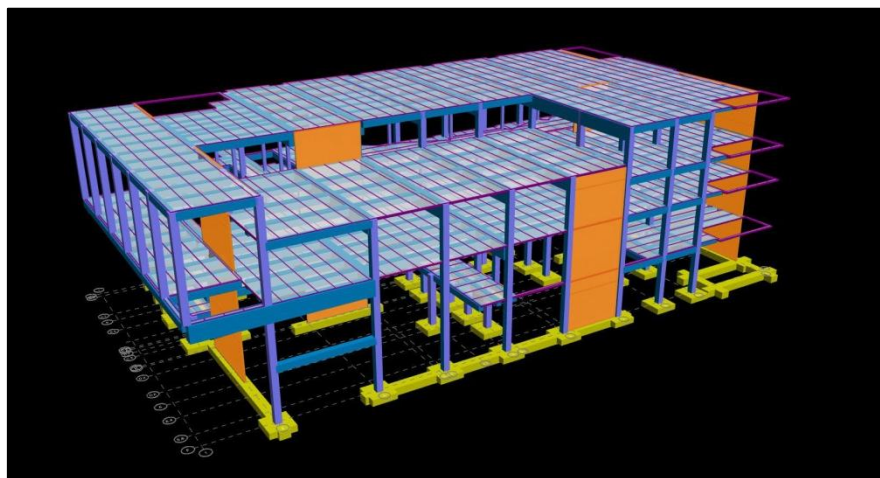

Figure 18: 3D view with shear walls in orange, other walls eliminated for visibility.

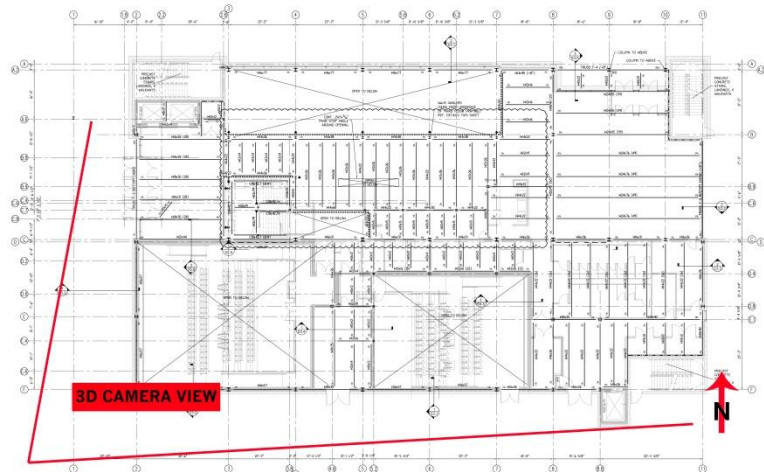

Figure 17: Camera view for 3D images

To follow a logical design process, the gravity system was first designed, starting with the slab and decking system being replaced by a one-way slab system, with beams and girders being redesigned in concrete. A controlling bay from each floor was chosen and designed, and these results are elaborated on below in

the Gravity Redesign portion of this chapter. After the bays were designed, controlling columns were designed and the size estimated for the above calculations were confirmed or adjusted as necessary. Once the gravity system was designed, the lateral system, comprised of shear walls in both directions and highlighted in Figure 18, was analyzed and designed.

RAM Structural System (RAM) was used to develop full gravity and lateral models, and these were confirmed via the hand calculations. The use of RAM helps to meet the MAE requirements of this thesis. The development of the model will be explained more thoroughly in the appropriate portions of this thesis.

## 2.1 Gravity Redesign

This redesign minimizes changes in the architectural layout, while focusing on specific bays and structural components that control structurally. Due to the architectural features and design controlling layout, none of the floors have the same diaphragm, as seen in Figure 19. For a clearer understanding of the chosen bays and places of focus, it is necessary to develop a thorough understanding of where the controlling areas are and where concrete can benefit the current building layout.

As can be seen highlighted in Figure 19, fifty foot spans exist on many of the floors, as well as cantilevered areas highlighted in blue. These areas are benefitted by the use of concrete, which naturally utilizes back spans in the layout to strengthen cantilevered sections. The gravity redesign incorporates some of these controlling factors. Existing design includes hanging columns on the fourth floor and second floor, and elimination of these (and replacement by cantilevers) is evaluated.

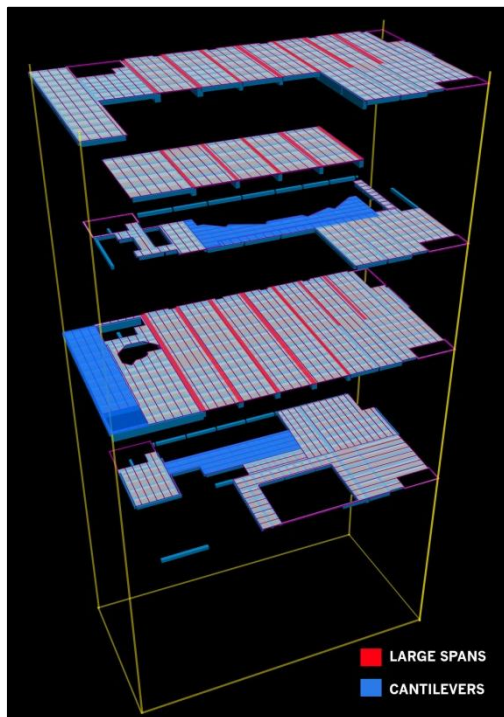

**Figure 19:** Expanded view highlighting focus spans and cantilevers.

Floor to floor height is another added benefit to concrete. Since these floors have large ceiling heights for space use and aesthetics, any additional space saved within the structural system is important. By utilizing concrete, structural floor to floor height could be saved while maintaining architectural ceiling height and minimizing some cost.

Acoustic isolation is naturally a benefit of concrete on each of the primary spaces. This is in contrast to the existing steel system, which requires additional acoustic control and sound isolation. The benefits to the acoustics of the spaces will further be considered in Chapter 3: Acoustic Breadth.

Since floor plans are not consistent from floor to floor, a controlling bay from each floor was first designed to develop a floor slab depth and typical bay design, as can be seen in Figure 20. A one-way slab system has been developed for the SSPAC, with series of beams and girders taking this load into the columns.

Ram was utilized for aiding in the design of the gravity system. Initially, the model was created with the existing dimensions and layouts, with gravity member sizes estimated based on preliminary hand calculations. Once this preliminary design was in place, it was run to check member sizes for the loadings assigned. Iterations followed, including reinforcement design and placement of members adjusted accordingly. These methods and results are elaborated below for each type of structural component.

Hand calculations, including the use of a spreadsheet, for the slab depth, beam sizes, and girder sizes were utilized to confirm the output loads and designs from RAM. These resulting structural component sizes were then updated in the RAM model and concrete and reinforcement design were confirmed through the RAM Concrete design module.

Due to the inconsistency of bay sizes, the use of ACI 318-11 §8.3 cannot be used for all moment estimations, except to confirm appropriate magnitude, which was done where possible. Therefore, the RAM model analysis was confirmed for output of moments and shear by modeling a beam line from the mechanical roof in STAAD. General assumptions made on the gravity model are as follows:

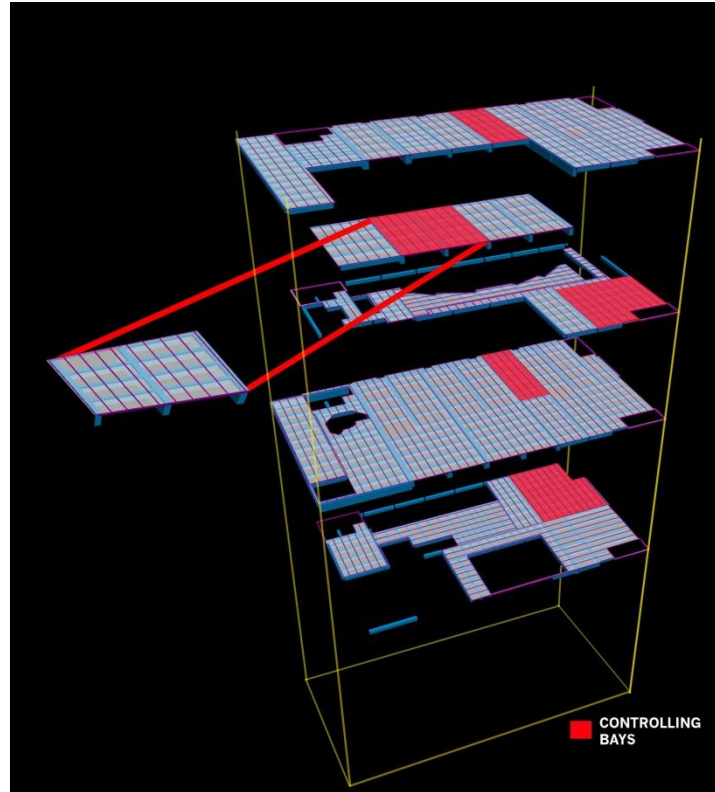

Figure 20: Primary spaces highlighted, mechanical roof bay as example.

This cast-in-place concrete system is monolithic. Therefore, connections between slabs, beams, and columns are fixed.

Deep beam issues, torsion, and shear are all taken into consideration.

For the purpose of this report, the bay chosen from the mechanical floor will be highlighted for explanation of the design procedure and confirmation of hand calculations and the RAM Structural System model. This can be seen in Figure 20. As the mechanical roof has a typical loading and bay width, with larger bay depths, it is a reasonable bay to use throughout the report. Full calculations and results for each of the controlling bays and structural components can be found in Appendix D.



### 2.1.1 Beams & Slabs

The highlighted bays still control for loading and beams, and therefore the beams adjoining each of these bays have been designed. The mechanical roof beams and girders are highlighted in red, with the slab highlighted in blue in Figure 21.

The diaphragm system was designed and chosen considering the results of a system comparison. Due to the results of past system comparisons (see Technical Report II), and the existence of large spans, the systems considered at greater depth in this report are a reinforced concrete one-way slab system and a prestressed one-way slab system. Because of the direct comparison desired, the column lines were not reconfigured to match each potential system, but reconfigured to be good for both. In reality, once the diaphragm system was chosen, the column lines would possibly be further adjusted. Each of the systems are elaborated on below and then compared for final design results. The prestressed system lends towards completion of the MAE component of this thesis, as explained further.

The same area on the mechanical roof will be discussed for the most accurate comparison of the two systems. Important considerations for each of these designs included deflection, system depth, kept at or below the existing system depth, and cost considerations. These are evaluated and compared below.

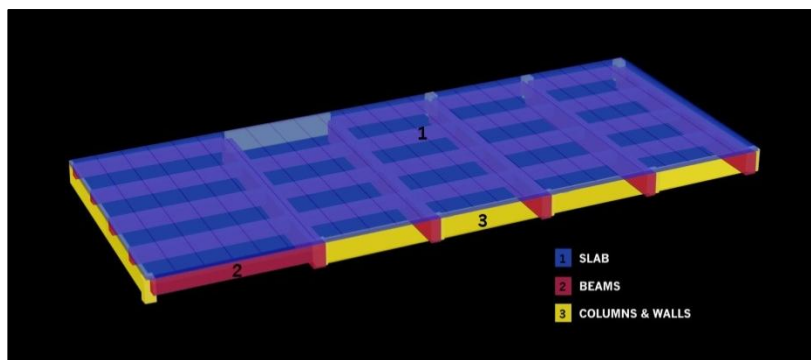

Figure 21: Mechanical roof

### Reinforced Concrete Slab and Beam Design

The use of a one-way reinforced concrete system dictates the use of beams and girders within each bay for the layout seen throughout the SSPAC. Therefore, this design starts with a slab depth, used at the

Table 12: Gravity redesign results

Gravity Design Results: Mechanical Roof			
Member	Dimensions	Location	Reinforcement
Slab	8"	Top/Bottom	#4s @ 8"
		Transverse	#4s @ 12"
Exterior Beam	26"x24"	Left Support	(4) #7s
		Midspan	(5) #6s
		Right Support	(4) #7s
Interior Beam	26"x24"	Left Support	(3) #9s
		Midspan	(3) #9s
		Right Support	(7) #10s
Girder	24"x54"	Left Support	(7) #10s
		Midspan	2 layers (8) #10s
		Right Support	(7) #10s

minimum for serviceability via ACI 318-11 §9.5.2 Table 9.5(a), which also considers deflection limits. For the mechanical roof, this was taken at 8 inches. Concrete strength for this system was taken at  $f'c = 4000$  psi.

From here, the layout of the beams was decided, and modeled appropriately in RAM, being supported along column lines by girders. Due to the use of large trusses in the existing steel system, these girders require heavy

designs to limit deflections and also maintain strength. As mentioned above, RAM was run through multiple iterations to design the most efficient system per bay.

To verify the integrity of the RAM output, hand calculations were performed simultaneously for the first set of beams and girders. These confirmations included that of loaded moments, designed sizes and reinforcement, and deflections. Due to the bay layouts, moments cannot be evaluated by the use of ACI Chapter 8 moment coefficient. Therefore, typical members were modeled in STAAD to confirm output values from the RAM Gravity Model. These programs resulted in output moments and forces with less than 5% variation. Hand calculations confirmed the accuracy of the RAM model for extrapolation to the design of the rest of the bays, as these design results saw a difference of results under 5%, which is considered adequate. These hand calculations and associated spreadsheets can be found in Appendix D.

This design resulted in 24" wide girders for the larger bays with a depth around 4' 6". This is comparable to the existing steel system, in that the depth of these girders is less than that of the trusses that are being replaced. A summary of the results for the mechanical roof can be seen in Table 12. The highlighted bay can be seen with typical dimensions in Figure 22.

Throughout the building, designs of the slabs and beams as a reinforced concrete system resulted in a system that is competitive with the steel framing system and the use of prestressed concrete system. As it is a cast-in-place concrete system, this also requires more on-site preparation during the construction process. Though this system does not eliminate many beams in some areas, it is an effective system for the larger spans, including both strength and serviceability considerations.

Yet, even with these concerns, benefits to this system are in primary locations of the structure. In using a

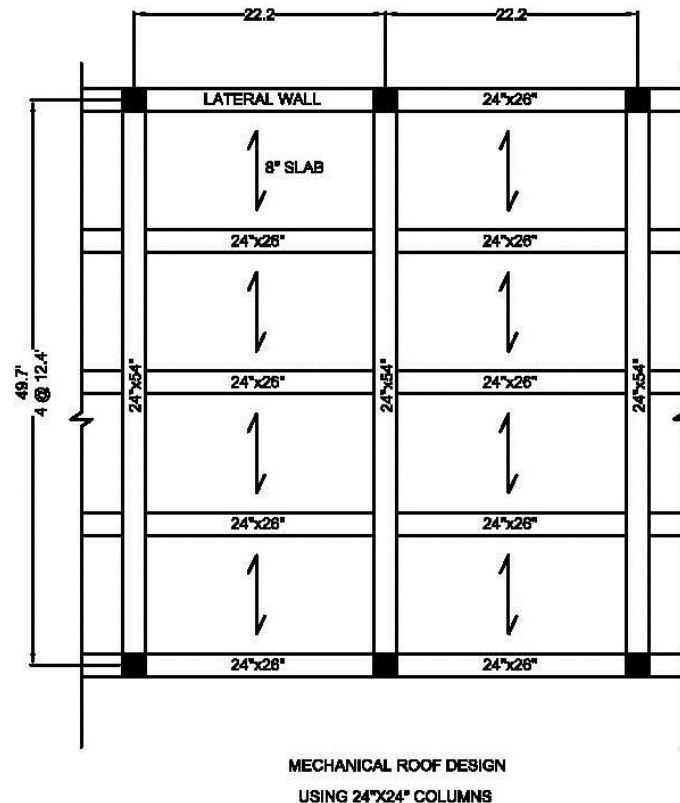

Figure 22: Reinforced concrete ne-way slab and beam system results

concrete system, a cantilever along the edge of the fourth floor mezzanine can be utilized. Compared to steel, which required the addition of beams along the edge of the slab, this is an added benefit, as edge beams can be eliminated and it would result in a visibly cleaner and more open look.

### Prestressed Design for Girders & Slabs

The alternative to reinforced concrete for the slab and beam system is to prestress the slab and girders, primarily for the larger bays seen throughout the floors. As deflections and member sizes were large, this alternative is seen as a plausible possibility to a reinforced concrete system.

First, member sizes were estimated by rule of thumb based on the moments. This gave an accurate estimate to the sizing that would be input into ADAPT-PT, the program being utilized to assist in designing the prestressing of each of these structural components. Using rule-of-thumb, the results from ADAPT-PT were confirmed as accurate. And include some of the following assumptions:

Concrete strength was  $f'_c = 5000$  psi.

$\frac{1}{2}$ "  $\emptyset$  270 ksi strength prestressing strand are utilized throughout. With this, the PT force was kept under a rule-of-thumb maximum of 600 ksi.

Issues such as creep were considered throughout the design process.

Design resulted in one-way slabs spanning between column lines, on average at 22.2' spans, with 8" slabs. The girders were designed as 3'6" due to serviceability limitation for the approximately 50 foot spans.

The tendon profiles for both

slab and girder design are included in Figure 25 and Figure 24, respectively, below. Table 13 gives a summary of both the prestressing and the mild reinforcement necessary in this design.

Benefits to this design include both serviceability and strength criteria. Within the bays, elimination of interior bay beams minimizes concrete and therefore even more floor-to-floor height than the above reinforced concrete system. Most of the building has an exposed structural system; this will aid in a much cleaner aesthetic, and will open up space for mechanical, electrical, and plumbing in these larger spaces.

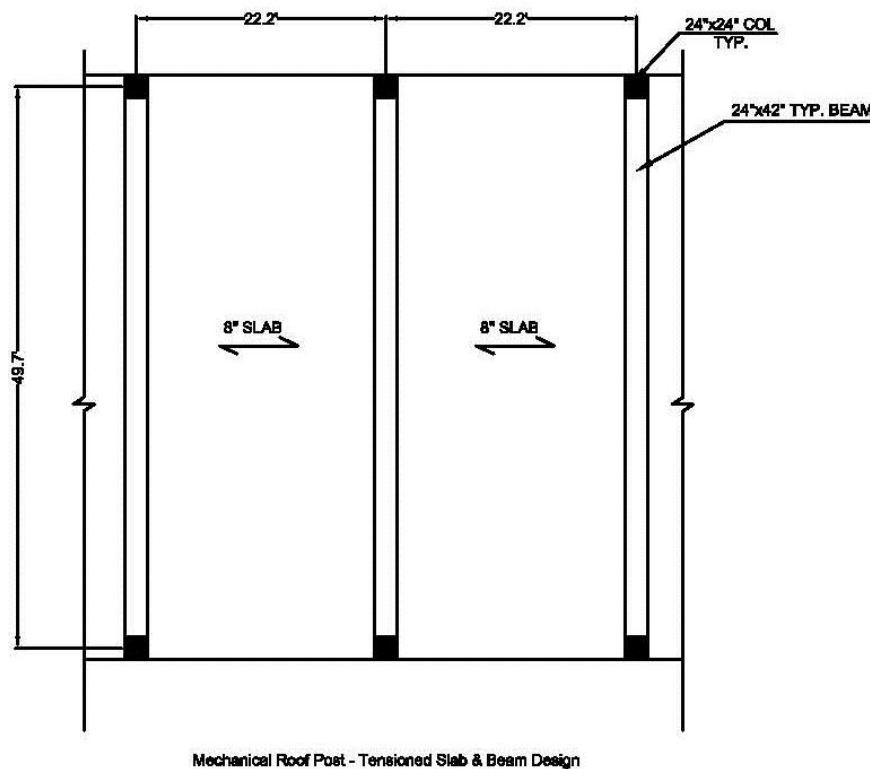

Figure 23: Prestressed one-way slab & beam system

Where two adjoining large spans are prestressed, moments will also be minimized. Though this does not include all of the bays, it does include much of the third floor and some of the mechanical roof, and is an added benefit to each of these floor systems. Because of this benefit, other spaces not originally considered for larger spans, would benefit from a two-bay prestressed system, so columns could be eliminated, especially where the column already does not follow through to the slab-on-grade.

It is noted that this system will likely be more expensive than the reinforced concrete system. This cost comparison, as well as a more thorough comparison of the two systems, can be seen below.

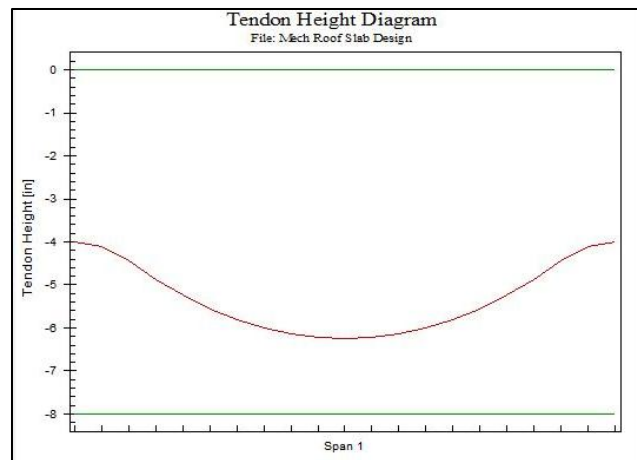

Figure 24: Tendon profile for prestressed slab

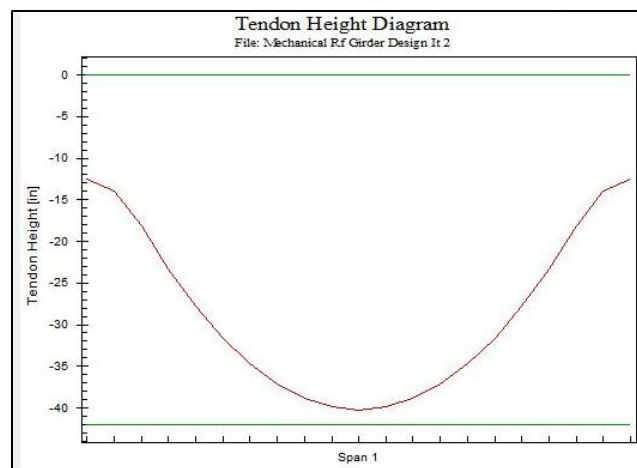

Figure 25: Tendon profile for prestressed beam

Table 13: Prestressed gravity design results

Prestressed Gravity Design Results				
Member	Dimensions	Location	Reinforcement	1/2" Ø Strands
Slab	8"	Top Upper	#7s @ 9"	@ 10" o.c.
		Top Lower		
		Bottom Upper	#4s @ 12"	
		Bottom Lower		
Beam	42"x24"	Top Upper	(9) #7s x 40'0"	(15)
		Top Lower	---	
		Bottom Upper	(2) #7s x 22'0"	
		Bottom Lower	(3) #7s x 50'0"	

## Comparison of Gravity Systems

These two slab and beam systems are more exhaustively compared through a cost analysis and through other design considerations. A side by side comparison of these systems is seen in Table 14.

The reinforced concrete system is the more viable system in terms of cost and construction. The prestressed system is a more challenging system in terms of cost and time, and would require additional on-site equipment. On the other hand, the prestressed system is an entire foot shorter per floor than the reinforced concrete system, and therefore allows for a higher architectural ceiling or additional material

**Table 14: System comparison**

Design Considerations		Existing Composite Steel System	Reinforced Concrete One-Way Slab and Beam	Prestressed One-Way Slab and Beam
Construction	Depth of Slab (in)	5	8	8
	Depth of System (ft)	7	4.6	3.6
	Cost (\$/SF)	17.93	17.96	19.64
	Fire Rating (hr)	1	1	1
	Fire Protection	Spray Fireproofing	None	None
	Schedule	N/A	Curing & formwork time required	Slightly more lead time; more coordination required
	Constructability	Moderate	Easy	Moderate - Difficult
Structural	Foundation	N/A	Approx same weight, no change in foundation considerations	
	Seismic Increase	N/A	Negligible Difference	
	Lateral	N/A	Negligible Difference	
Architectural	Impact	N/A	Floor-to-floor height better	Floor-to-floor height better, elimination of some columns possible
Serviceability	Deflection (in)	0.77	0.60	0.32
	Vibration Control	Satisfactory	Satisfactory	Satisfactory

cost savings. Columns can also be eliminated while minimizing some of the moment seen in the building due to these larger spans.

In light of these considerations as summarized above, the final design results in the use of prestressed slabs and beams where appropriate for the larger spans and bays, and for smaller configurations, one-way slab and beam systems were utilized. As the SSPAC was designed with architecture being a main focus, the aesthetic benefits of a prestressed system over a one-way slab and beam system are a control in this structural decision.

### 2.1.2 Columns & Gravity Walls

Both columns and gravity walls were designed for the concrete structural system. Where walls already existed, gravity or lateral walls were designed (see Lateral Redesign section of this chapter) as appropriate. Both axial and flexural loadings were considered when designing the members and their appropriate reinforcement. Loads were evaluated based upon load transfer from the chosen gravity system above, with hand calculations confirming RAM output loads.

#### Columns

Typical columns, supporting the controlling bays, were chosen for hand calculation and design. As can be seen in Figure 18, a series of columns and walls support the gravity system. Members being focused on in this design overview are highlighted in red in Figure 26.

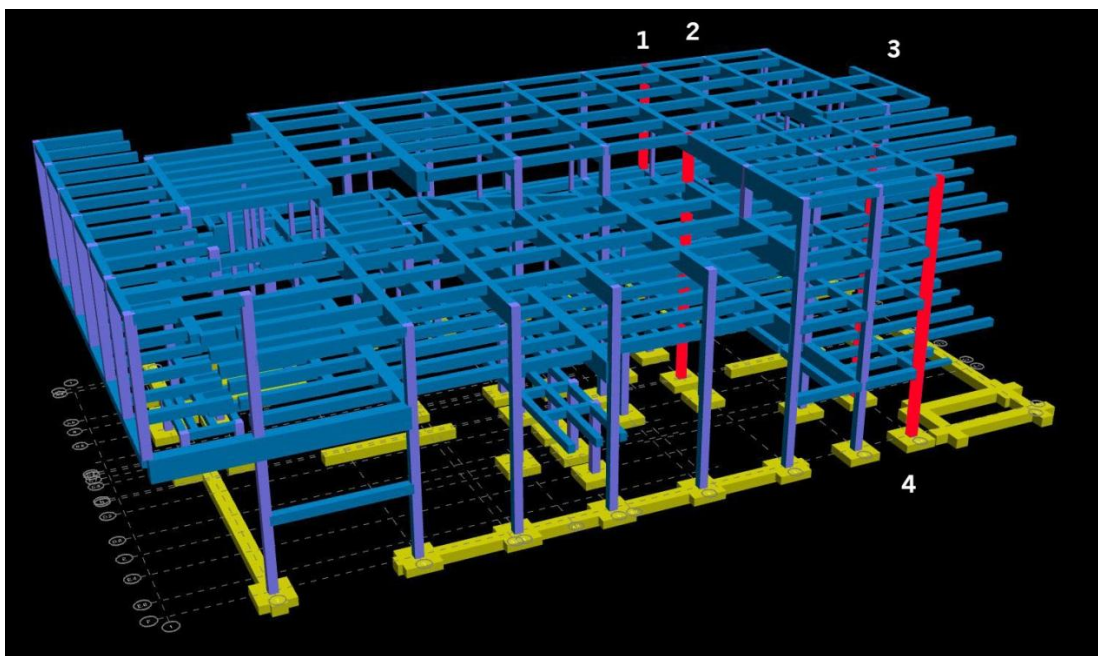

Figure 26: Highlighted columns designed by hand, walls eliminated

As above for the beam and slab system, primary columns were designed by hand calculations to confirm input and output from the computer model used, here StructurePoint Column, before continuing design. These hand results confirmed that, due to flexural loadings and the long unsupported length of many of the columns, some columns would require additional reinforcement and considerations.

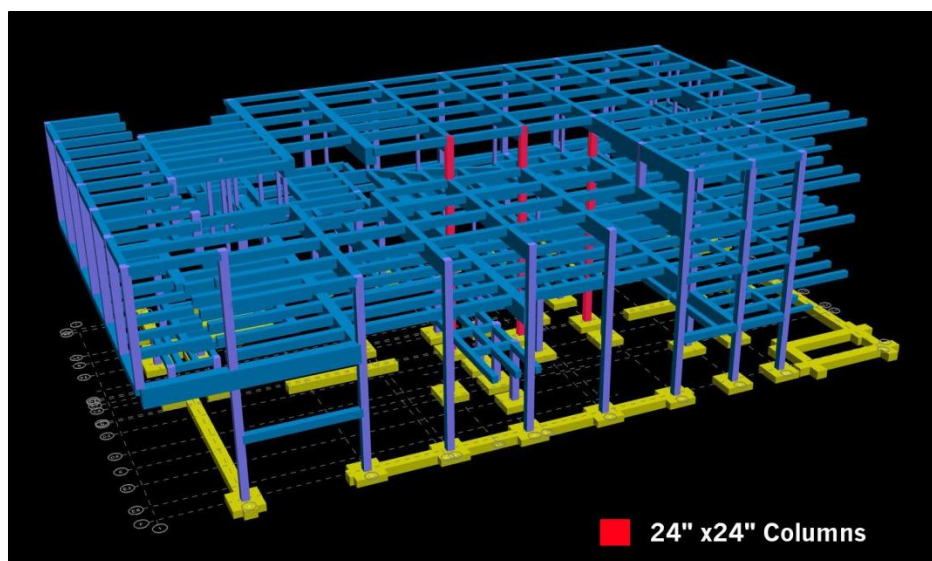

Figure 27: Resulting 24"x24" columns, walls eliminated

In all, columns were typically designed as 20"x20" members, with some variation in reinforcement based upon the loading. Columns along the central column line, as seen highlighted in Figure 27, were more heavily loaded, and design required these to be designed as 24"x24" columns with  $f'c = 6000$  psi. As these supports run along the center of the building and support larger spans on both sides, this is a logical outcome and does not impact the layout of the building. Results for the primary columns considered in this explanation are highlighted in Table 15.

Table 15: Gravity redesign results

Gravity Design Results: Mechanical Roof				
Member	$f'c$ (psi)	Dimensions	Location	Reinforcement
<b>F8.8</b> (exterior)	4000	20"X20"	Longitudinal Transverse	(6) #9s #4s @ 12"
<b>E8.8</b> (interior)	4000	20"X20"	Longitudinal Transverse	(6) #9s #4s @ 12"
<b>A-8</b> (exterior)	4000	20"X20"	Longitudinal Transverse	(6) #9s #4s @ 12"
<b>C-7</b> (interior)	6000	24"X24"	Longitudinal Transverse	(16) #9s #4s @ 12"

One primary benefit to a concrete system over a steel system for columns is that the concrete columns have a higher stiffness and therefore resist more against flexure and therefore p-delta effects. It is noted however, that steel members are narrower and have less impact on the architecture.

## Walls

Gravity walls were designed after the lateral system was decided on and required shear walls locations were confirmed, as discussed further in Lateral Redesign. The existing building includes gravity infill walls along the interior and exterior of the building, surrounding the cinemas and vertical circulation shafts. These walls were redesigned in concrete to maintain the same thicknesses as the original structure. A typical gravity wall result is seen below in Figure 28.

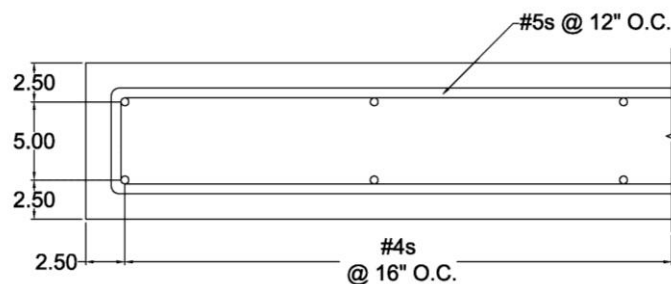

Figure 28: Typical gravity wall design

### 2.1.3 Foundations

Once the building had been designed, foundations were reevaluated for the new loadings. Due to a concrete system, the loadings on the foundations were slightly higher. A combination of axial and flexural load was evaluated for this heavier loading. In addition, uplift was considered where applicable. Some locations, with the heavy loading, eliminated uplift issues. For this, the foundations at the bases of the columns that were previously designed were designed. These design calculations can be found in Appendix D.

Overall, it was found that square foundations could be designed for a similar dimension, with additional reinforcement. Added benefits to this are in terms of the existing location, where existing site conditions are important and needed to be considered. Strip footings, under the walls, did not require additional dimensions, and were deemed adequate, with depth based on necessary site conditions. A summary of typical foundation results can be found in Table 16.

Table 16: Foundation design results, by hand

Foundation Design					
Type	Location	f'c (psi)	Dimensions	Reinforcement	Depth
Square	F8.8	4000	8' x 8'	(8) #6 ea. way	1'2"
Strip	Line F	4000	4.5' width	(7) #5s	1'4"



### 2.1.4 Design Summary

In conclusion, replacing the existing steel system with a concrete system has many benefits to the current building function needs. Strength requirements are met with a system that, though heavier, allows for flexibility in design of various cantilevers in the building. Also, due to the inconsistent layout of these spaces, concrete is a competitive option that has configuration flexibility that results in an effective design.

As has been developed above, a bay from the mechanical roof was detailed and designed, then explained thoroughly. The existing steel frame system included deep trusses to support these large spans. In place of these, large prestressed members were designed to a smaller depth. These met both strength and serviceability criteria. By using prestressed slabs and beams, many of the beams within bays were eliminated, freeing up space for mechanical, electrical, and plumbing, and giving the space a cleaner aesthetic. With the number of large spans over 45 feet summing up to more than 25 spans, the architectural requirements, and the forces seen on the system, the prestressed system was concluded as the better option.

Columns and gravity walls were designed effectively, with results for columns usually seen at 20"x20", with the central column line being designed as 24"x24". Gravity walls were designed similar to the existing in size and location, with the exception of now being cast-in-place instead of precast.

In relation to serviceability, 6 feet of floor-to-floor height is also saved throughout the total height of the structure. This floor-to-floor height already considers the layout of the mechanical, electrical, and plumbing systems, which reach the building spaces through a primary shaft in the middle of the building and is not largely impacted by the redesign. It is suggested that this additional space saved be eliminated from the building to minimize costs, but could also be utilized to create a higher architectural ceiling.

Even though this was a successful redesign, certain areas of the building lend more towards the existing steel system, and this was seen throughout the redesign. This includes the sets of hanging columns on the second and fourth floors, which would have to be adjusted into cantilevers, standard columns, or larger transfer girders. Another example of steel being a better system is in the spiral staircase, located between the second and fourth floors, and is a much better system in steel that would need to be changed to be efficiently designed in concrete.

The final designs for each of the bays chosen, as highlighted previously are given in the images following. It should be noted that the bays taken from the roof and third floor utilize the prestressed system, the fourth floor bay using a typical reinforced one-way system, and the bay chosen from the second floor is an integrated approach. Overall, each of these varies uniquely from the others, but all show the integration of prestressed bays into the typical concrete system.

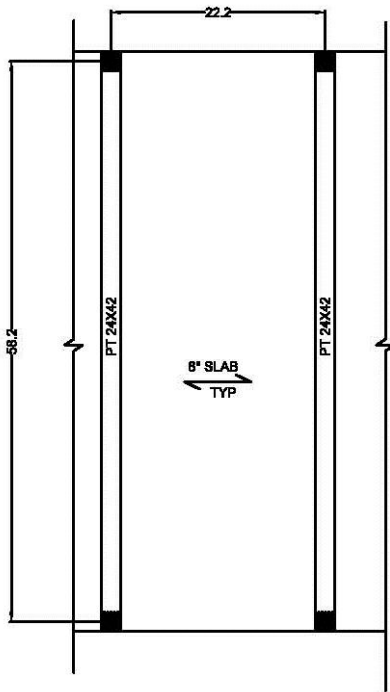

ROOF - PRESTRESSED

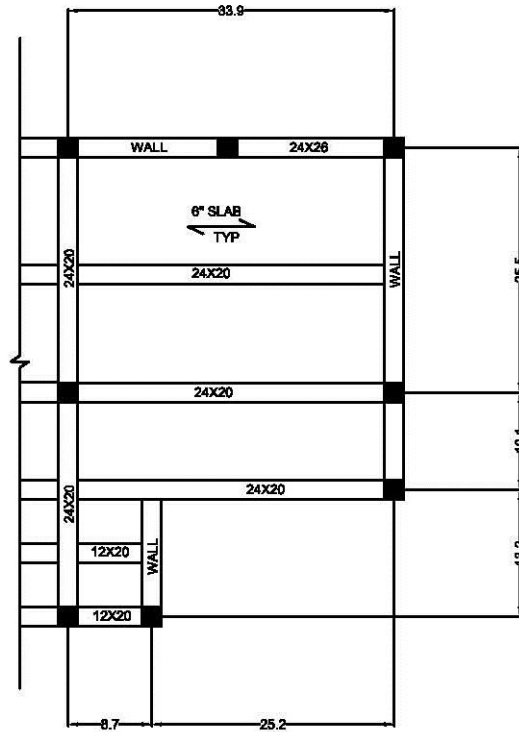

4TH - ONE-WAY SLAB AND BEAM

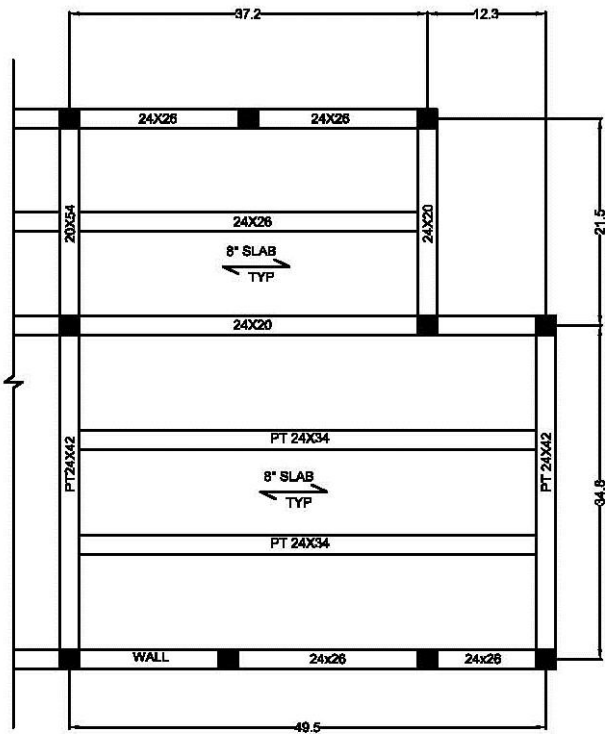

2ND - PRESTRESSED

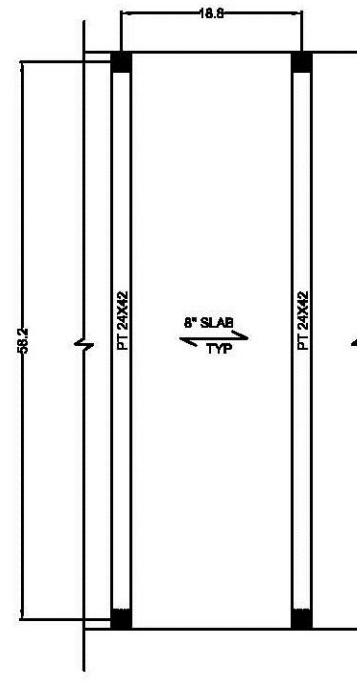

3RD - PRESTRESSED

## 2.2 Lateral Redesign

Due to the gravity system being redesigned as a concrete system, the lateral system will also be changed. Braced frames, already existing in interior wall locations, were replaced by concrete shear walls. Shear walls are also slightly reconfigured to minimize torsion that contributed largely to lateral load in the existing building. Iterations were completed to find the best layout, as can be seen in Figure 29. While formerly shear walls were precast, they are being reevaluated as part of the cast-in-place system. For evaluation of the lateral loads, a RAM model was built, loads applied, and then shear walls were designed based on the resisting forces found in each wall. Supporting calculations can be found in Appendix E and Appendix F.

### 2.2.1 RAM Input & Confirmations

The lateral system was essentially left in the same layout as previously, and this new system can be seen in Figure 29, which highlights the shear wall configuration in orange. The lateral system was created in RAM, allowing for a complete frame analysis of the model. The input for this RAM model is similar to that of the existing structure, but with a more limited shear wall system, higher torsional issues are considered.

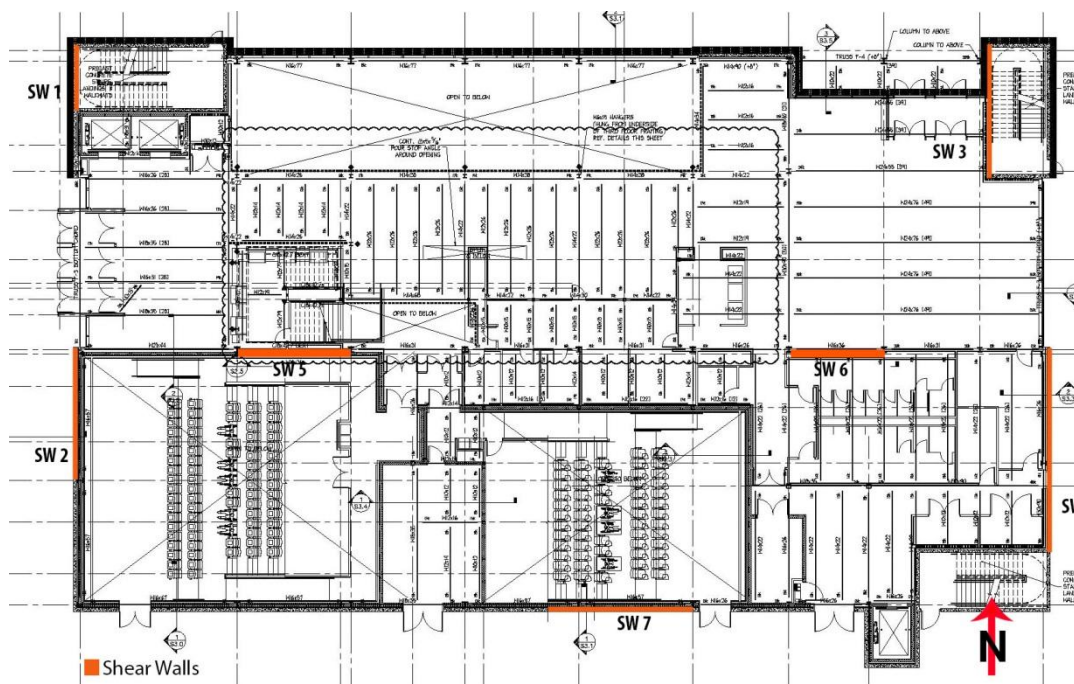

Figure 29: Lateral walls, highlighted

The RAM model incorporated into the analysis of the lateral system of the SSPAC allowed for several assumptions that impacted the results obtained from the model. The theory and code behind these assumptions dictated more accurate analysis results. Some of the primary assumptions are as follows:

Floor systems were input into RAM as a rigid diaphragm, which guaranteed that all points would deflect together.

All cast-in-place concrete was treated as a monolithic system, and assumptions for fixed joint connectivity followed ACI Code allowance. Connections at foundations were also assumed to be fixed.

For the concrete shear walls, cracked sections were considered, as per ACI §8.8.2, wherein the gross section was minimized to 70% to model the area for the cracked section.

P-Delta effects were considered in the lateral analysis, as required by chapters 12 (seismic) and 6 (wind) in ASCE 7-05.

### Torsion

Vertical structural irregularities were considered for the SSPAC, applicable ones from ASCE 7-05 Table 12.3-2 including in-plane discontinuities and weak story irregularities. Neither is an issue in the SSPAC, and both have been confirmed to not exist. Therefore, vertical structural irregularities do not apply to the structure.

After confirmation of the RAM model's accuracy through building property output and hand calculations, seen in Appendix E and Appendix F, torsion was then considered. Noting the differences in the center of mass and center of rigidity, it could be seen that torsion would impact the structure.

Horizontal irregularities, as they existed in the existing model, were also an important factor in the lateral design. Both torsional irregularity and extreme torsional irregularity, as defined by ASCE 7-05 Table 12.3-1, needed to be considered for the SSPAC. Therefore, the RAM model considered a 5% eccentricity, but hand calculations were implemented to establish the need for use of the torsional amplification factor. The method utilized for this procedure is outlined in ASCE 7-05 Figure 12.8-1 and is more thoroughly explained in Technical Report III.

As was found in the existing structure, the X-Direction had no torsional irregularity. In the Y-Direction, torsional irregularity was found, and each of the corresponding amplification factors was then applied to recalculate the moment that was then reapplied to the SSPAC RAM model. Torsional irregularity in the Y-Direction is a result of the longer building cross section, large moment arm produced by the center of rigidity, and the irregularity of the geometry. Yet, compared to the existing system, some torsion was eliminated in the Y-direction; instead of creating an extreme torsional irregularity, only torsional irregularity now exists as an added benefit to the reconfigured shear walls. A summary of these results can be seen in Table 17, with detailed hand calculations found in Appendix E.

**Table 17: Torsional amplification factors applied**

	Y-Direction Accidental Torsion				Resulting Moment and Bx' (ft-k)		
	Bx	5% Bx	Ay	Mzy	Mzy'	Bx'	
Roof	190	9.5	1.3	2208.8	2800.8	294.8	
Mech Roof	190	9.5	1.0	1270.2	1270.2	133.7	
4th	190	9.5	1.3	1352.8	1711.9	180.2	
3rd	190	9.5	1.2	2883.3	3498.8	368.3	
2nd	190	9.5	1.2	676.7	790.5	83.2	
Ground	N/A	N/A	N/A	N/A	N/A	N/A	
	Overturning Moment (ft-k)			8391.6	Overturning Moment (ft-k)		10072.1

## 2.2.2 Applied Building Loads

Once the building was modeled, both wind and seismic loads were calculated. Previously, as can be seen in the explanation in Chapter 1, seismic controlled. It was assumed that seismic would again control, especially as the building is heavier than before. As wind is based on height, these essentially changed very little. Seismic loads, based on the building weight, as can be seen below, were recalculated to be heavier loads than before. Serviceability requirements were checked with each lateral loading, and are elaborated below as well.

### Wind

As stated previously, wind load calculations for the structure redesign do not result in much variation from the existing wind loads, as seen in Chapter 1.5. A summary of these loads, applied in both North-South and East-West directions can be seen in Table 18, with calculations for these adjusted values seen in Appendix E.

Table 18: Wind loading results

Wind Loadings						
Windward Wall	Location	Height	North-South		East-West	
			Story Shear (k)	Overtuning Moment (k-ft)	Story Shear (k)	Overtuning Moment (k-ft)
	Roof	58	21.59	1252	11.41	661.57
Floor 4	45	63.47	1884	22.02	990.78	
Floor 3	32	110.06	1491	24.36	779.41	
Floor 2	15	159.57	743	25.87	388.11	
Ground	0	182.78	0	12.13	0.00	
Width (ft)	190					
Total Base Shear (k):			182.78		95.78	
Total Overtuning (k-ft)			4628		2432	

Drift calculations for serviceability needed to be met under wind loads, as per the rule of thumb H/400 found in ASCE 7-5 §C-C. As found previously, the building is a fairly stiff building without drift issues. These results can be found in Table 19.

Table 19: Drift & displacement results, wind loading

Wind Drift & Displacement										
X Direction	Level	Story Height	h <sub>sx</sub>	Story Drift, Δ			Total Displacement, δ			Controlling Load Case
				Story Drift, Δ (in)	Δ <sub>max, rel</sub> (in) = Δ / h/400	Δ < Δ <sub>max</sub>	Total Displ, δ (in)	δ <sub>max, rel</sub> (in) = δ / h/400	δ < δ <sub>max</sub>	
X Direction	Roof	58	11	0.01633	0.330	YES	0.05922	1.740	YES	W1
	Mech Roof	47	16.5	0.00125	0.495	YES	0.04289	1.410	YES	W1
	4th	45	13	0.01594	0.390	YES	0.04164	1.350	YES	W1
	3rd	32	17	0.01729	0.510	YES	0.0257	0.960	YES	W1
	2nd	15	17.5	0.00841	0.525	YES	0.00841	0.450	YES	W1
	Y Direction	Roof	58	11	0.00375	0.165	YES	0.04197	0.870	YES
Mech Roof		47	16.5	0.00968	0.248	YES	0.03822	0.705	YES	W2
4th		45	13	0.00829	0.195	YES	0.02854	0.675	YES	W2
3rd		32	17	0.01368	0.255	YES	0.02025	0.480	YES	W2
2nd		15	17.5	0.00657	0.263	YES	0.00657	0.225	YES	W2

## Seismic

Seismic loads controlled, as was anticipated, since when the weight of a building increases, the seismic loads also increase. For these load calculations, the building weight was recalculated and the RAM model was confirmed to be accurate in load and self-weight calculations. Seismic loads followed the same procedure outlined in Chapter 1.5 of this report, and results from this procedure can be found in Table 20.

Table 20: Seismic load results

Seismic Forces							
Level	Story Weight, $w_x$ (kips)	Story Height, $h_x$	$w_x h_x^k$	$C_{vx}$	Story Force (k) $F_x = C_{vx} * V$	Story Shear (k)	Overturning Moment (k-ft)
Roof	3167.9	58	287,198	0.301	245.8	245.8	14254
Mech Roof	1361.13	47	97,708	0.103	83.6	329.4	15481
Floor 4	2025.8	45	138,566	0.145	118.6	447.9	20158
Floor 3	6366.1	32	298,256	0.313	255.2	703.2	22501
Floor 2	6495.0	15	131,232	0.138	112.3	815.5	12232
Ground	N/A	0	N/A	N/A	N/A	N/A	N/A
Cs	0.042				Base Shear $[V = C_s * W]$ (k)		815.5
W(k)	19416				Total Overturning Moment (k-ft)		84626

Serviceability requirements were evaluated for seismic. Under heavier loadings, seismic drift increased from the previous system, yet these drifts are still well under drift allowances as per ASCE7-05. It can be remarked that less walls are being evaluated as shear walls, and therefore, while overall the building is stiffer as a fully concrete system, only the lateral system is considered as resisting load, and only a portion of the current shear walls system are necessary for lateral loads. These drift values are summarized in Table 21.

Since seismic loads control, these are the loads used in this design. Application of these specific loads to the SSPAC are elaborated on in the following few sections.

Table 21: Drift & displacement results, seismic loading

Seismic Drift & Displacement: Amplification Factor, (Cd/I) Factor Considered									
X Direction				Story Drift, $\Delta$			Total Displacement, $\delta$		
	Level	Story Height	$h_{sx}$	Story Drift, $\Delta$ (in)	$\Delta_{max, rel} (in) = \Delta < \Delta_{max}$	$.015 h_{sx}$	Total Displ, $\delta$ (in)	$\delta_{max, rel} (in) = \delta < \delta_{max}$	$.015 h_{sx}$
	Roof	58	11	0.833	1.98	YES	2.849	10.440	YES
Mech Roof	47	16.5	0.059	2.97	YES	2.016	8.460	YES	
4th	45	13	0.778	2.34	YES	1.957	8.100	YES	
3rd	32	17	0.826	3.06	YES	1.179	5.760	YES	
2nd	15	15	0.353	2.70	YES	0.353	2.700	YES	
Y Direction				Story Drift, $\Delta$			Total Displacement, $\delta$		
	Level	Story Height	$h_{sx}$	Story Drift, $\Delta$ (in)	$\Delta_{max, rel} (in) = \Delta < \Delta_{max}$	$.015 h_{sx}$	Total Displ, $\delta$ (in)	$\delta_{max, rel} (in) = \delta < \delta_{max}$	$.015 h_{sx}$
	Roof	58	11	0.098	1.98	YES	1.161	10.440	YES
Mech Roof	47	16.5	0.286	2.97	YES	1.064	8.460	YES	
4th	45	13	0.244	2.34	YES	0.778	8.100	YES	
3rd	32	17	0.375	3.06	YES	0.534	5.760	YES	
2nd	15	17.5	0.159	3.15	YES	0.159	2.700	YES	

### 2.2.3 Load paths

Because of the complexity and irregularity of the building layout, load paths need to be thoroughly understood and evaluated. Goals of understanding the load path more completely:

- Look at areas of connection between shear walls and diaphragms throughout the floors
- Highlight areas of larger concern (e.g., coupling beams, transfer girders)

For an easier explanation, the results of this load path evaluation will be elaborated on by applying the controlling lateral load in the east-west direction, as seen in Figure 30. This figure displays the lateral load, first applied in red, which transfers through each of the floor diaphragms and then to the shear walls.

As can be seen in the load path figure, the diaphragms are not simply laid out, but are altered for each floor and a good portion can be considered irregular. These irregularities not only create torsional issues, but issues in transferring lateral loads through the diaphragms and into the shear walls by having good connectivity. By looking at this, locations can be seen where issues may arise out of poor connections.

Areas that cause concern are places where the diaphragm may be weaker, as seen on the fourth mezzanine by the thinner slab at the center, or where the walls carrying large amounts of lateral loads have a small connection point to the diaphragm. Here in the east-west direction, these places are highlighted in Figure 31.

Though diaphragms were considered rigid based on assumptions stated previously, further study would also look at additional stiffeners in some of these areas. Additionally, collectors at ends of shear walls and coupling beams between shear walls would require evaluation and further study. These areas are circled in Figure 31.

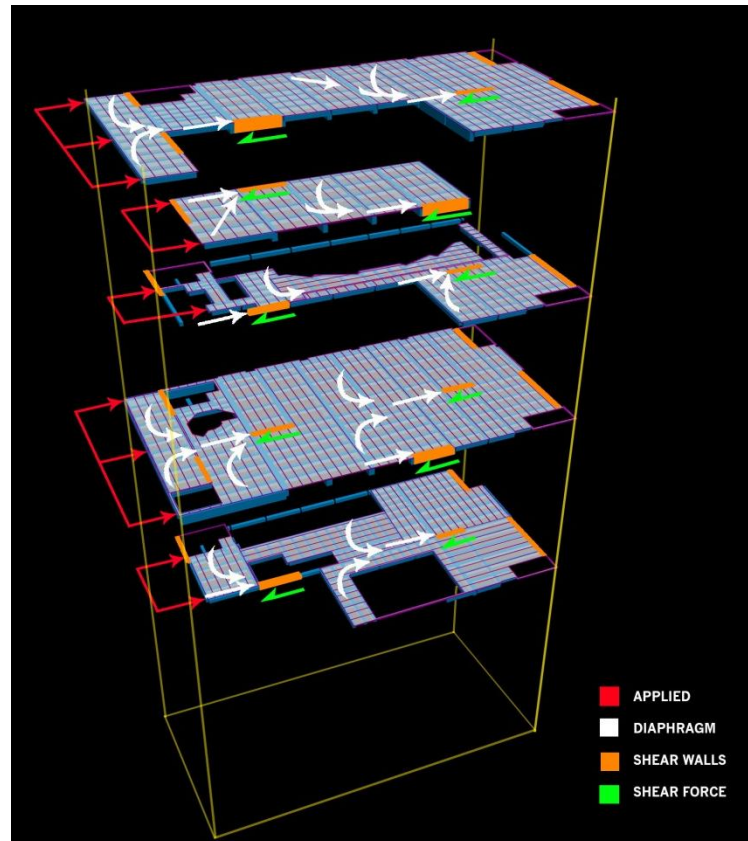

Figure 30: East-west load path

Once these areas are detailed, shear walls follow next in the load path, and seen highlighted in orange in Figure 30. Here, a typical shear wall, one that controls in torsion due the building eccentricity, is highlighted in Figure 32. The design of this and other shear walls are elaborated on in the next section.

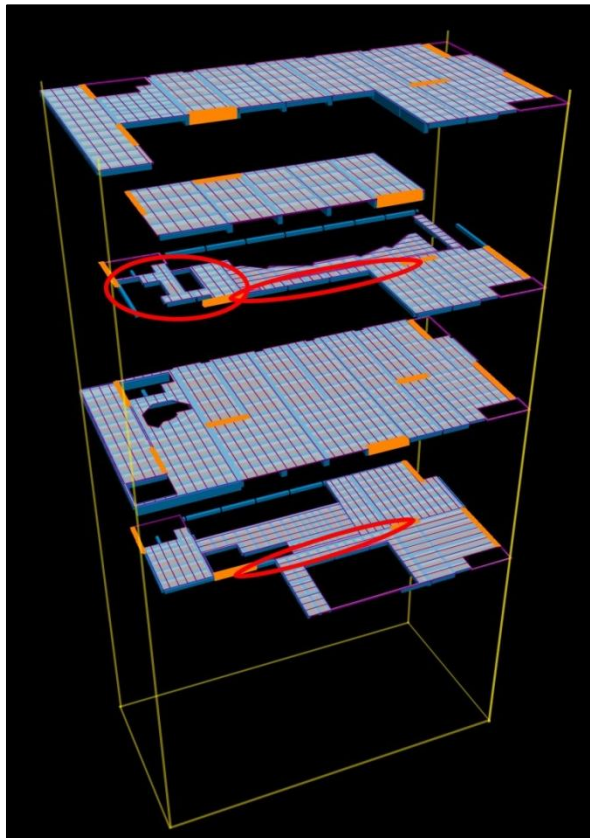

Figure 31: Lateral system details to be considered further

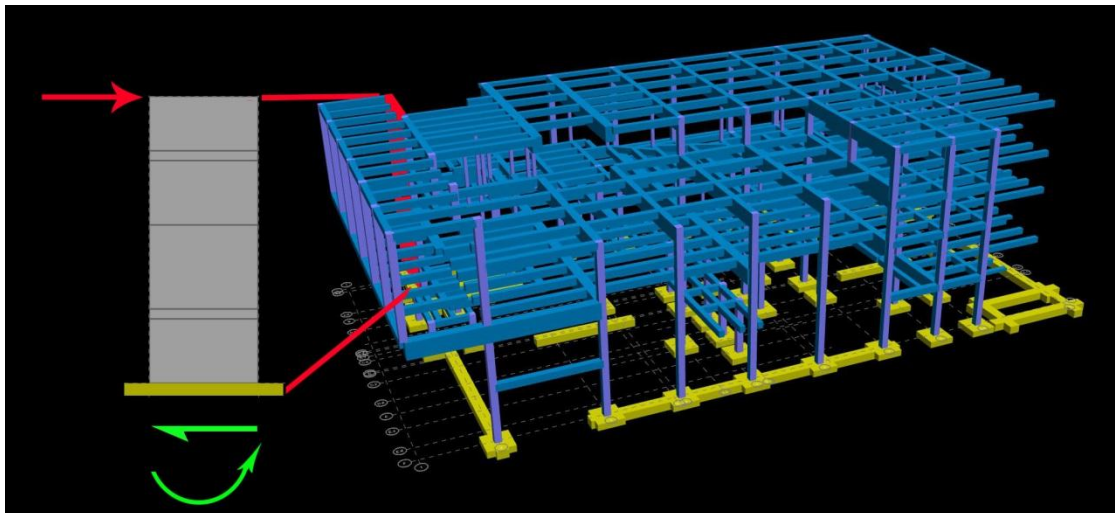

Figure 32: Shear wall highlighted



## 2.2.4 Design Results

Lateral loads, once taken through the diaphragm, transfer through to the shear walls, which are the primary component of the lateral system. RAM was not simply told to design shear walls, as it is not good to use a computer program without confirming assumptions the program is using. Loadings were confirmed via hand estimates of building loads and reactions. Hand calculations were completed on shear walls for design, with a thorough understanding of potential diaphragm issues related further as well.

Existing shear walls were designed as pre-cast panels. Because of the nature of the redesign, these will be cast-in-place, and were designed to be the same thicknesses as the existing walls. In addition to shear walls, locations along the diaphragm would also need to be detailed for higher stresses and loads. These are commented on previously.

### Shear Walls

In designing shear walls, maximum shear, which included consideration of interstory shear, overturning moment, and flexural loadings were accounted for. Shear walls are similar to cantilevered beams, and therefore are designed similarly. The wall being elaborated on here is highlighted in Figure 29 above, designated “SW 1” was chosen for its critical location and higher torsional issues.

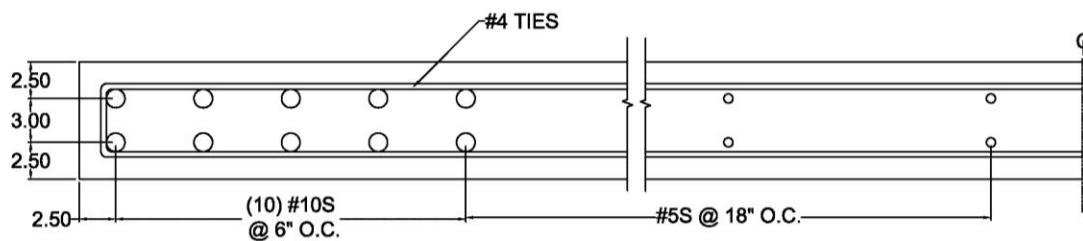

Figure 33: Typical shear wall detail

In summary, the lateral system, comprised of concrete shear walls, was redesigned to be 8” to 10” thick walls, matching thicknesses of the existing system. These shear walls are located at the existing braced frames and existing precast shear walls. Results are in Figure 33. See Appendix F for hand calculations.

Due to the torsional issues as explained more thoroughly above in Section 2.2.3 of this report, lateral loads create strong torsion in certain areas. The shear wall highlighted above is one with a larger torsional force due to its location and interaction with the existing diaphragms.

## 2.3 Comparison

As part of the focus of this thesis, a comparison of the existing system to the redesigned system is necessary to have a thorough understanding of the redesign. This portion of the comparison focuses on the structural advantages and disadvantages, with the implications this new system makes on other aspects of the building process.

While not every impact of the structural system was analyzed to great depth, each has been considered and evaluated for understanding of how these are impacted. Benefits and disadvantages on each of these systems to the redesign in concrete are discussed below.

### Gravity Design

As discussed throughout the gravity redesign, concrete lends towards certain design elements in the building. Some of these include cantilevers with back spans, which are located in various parts of the SSPAC, varied bay configurations, and large spans. The use of a prestressed concrete system is a benefit to the larger spans and moments associated with these.

It is acknowledged that certain elements of the SSPAC are more adapted to a steel building. The existing system has multiple locations where hanging columns exist, to open spaces on the floors below. While various solutions exist in concrete – transfer girders, cantilevers, standard columns – these are not as ideal or adventitious as the steel counterpart. These can be designed, but may require the layout to be altered or result in a more expensive option.

### Lateral Design

Benefits to using cast-in-place shear walls as the entire lateral system are seen in the stiffness of the building, as well as the cohesion between the gravity and lateral systems. There is less redundancy in this system, as compared to the existing design. This helps minimize cost, but in design against building failure, more redundancy is more conservative. The existing steel system has redundancy between the lateral and gravity systems, and though this is a good design, it is unnecessary for a concrete system.

Torsion, an issue in the existing system, was reevaluated for a slightly different shear wall configuration, and some of the extreme torsion inherent in the building was eliminated. Removal of torsion aided in making the redesign more efficient and therefore less expensive.

### Cost

Two brief cost analyses were produced, as discussed above in this chapter, as well as following in the related breadth sections. These cost comparisons showed that the chosen designs of normal reinforced concrete and prestressed one-way concrete systems, at \$17.96/ft<sup>2</sup> and \$19.64/ ft<sup>2</sup> respectively, though more expensive, were still competitive with the existing system, as \$17.93/ ft<sup>2</sup>. The cost, per square foot, of the existing system, is estimated in Appendix D, with the redesigns found in Table 14.

## Construction

Through the consideration of a concrete system, there is less lead time required, as opposed to steel. Concrete though, especially with the inclusion of prestressed bays, would take more construction time and require more site congestion.

## Other

There are other factors that control in this system, and are integrated into the overall performance of this building. Two of these, acoustics and architecture, are further discussed below in Chapters 2 and 3, and are tied tightly into the structural design.

It was found that the use of a concrete system could be developed with minimal changes to the layout, and the floor to floor height minimized. Because building weight was also an important factor for minimizing seismic loads which control laterally, this height change is another benefit to this system, which overall, is a heavier system than a steel system.

## 2.4 MAE Coursework Integration

Coursework requirements for the MAE were integrated well into this thesis, through knowledge gained in AE 530, *Computer Modeling of Building Structures*, and CE 543, *Prestressed Concrete Behavior and Design*.

Both the gravity system and lateral system were designed through the benefits of utilizing RAM Structural System, a structural analysis and design program that aids a competent engineer through a building design. As learned in AE 530, this program cannot be treated simply as a black box of input and output, but as a tool. While this speeded up the design process, hand calculations were also utilized to confirm that the software was being used appropriately and that code was being met through the input assumptions. An explanation of how this was incorporated can be seen earlier in Chapter 2.1-2.2.

The gravity system included an in-depth study of two different diaphragm systems, incorporating information obtained from CE 543. The slab and beam systems were not only designed as one-way slab and beam simply reinforced systems, but also as a prestressed system. Due to the large spans throughout the building, this option has many benefits and therefore is a competitive option. In summary, this design stems from knowledge obtained in CE 543, looking at the benefits and issues the use of prestressed concrete brings to an entire building system. This design process is explained in Chapter 2.1.1 more thoroughly.

## Chapter 3: Breadth I: Acoustics

As the SSPAC is a building full of various important acoustic spaces, a change in the structure and building materials will directly impact the success of each of these spaces. By eliminating steel and incorporating concrete, the new wall and floor systems will directly impact the effectiveness of sound isolation and room acoustics incorporated into the design. Therefore, the Reverberation Time (RT) of these spaces, and the Sound Transmission Criteria (STC) between these spaces and adjacent rooms will be evaluated. The RT is the amount of sound decay within a space due to the surface material reflectivity, and will be evaluated for the spaces most impacted by acoustics. With important spaces being adjacent to others, the Sound Transmission Criteria (STC), the sound transmitted between spaces, also needs to be evaluated, for confirmation that the space divisions meet requirements for the spaces. Each of these two components of the SSPAC acoustics is further discussed below. Supporting information and calculations can be found in Appendix G.

### 3.1 Reverberation Time

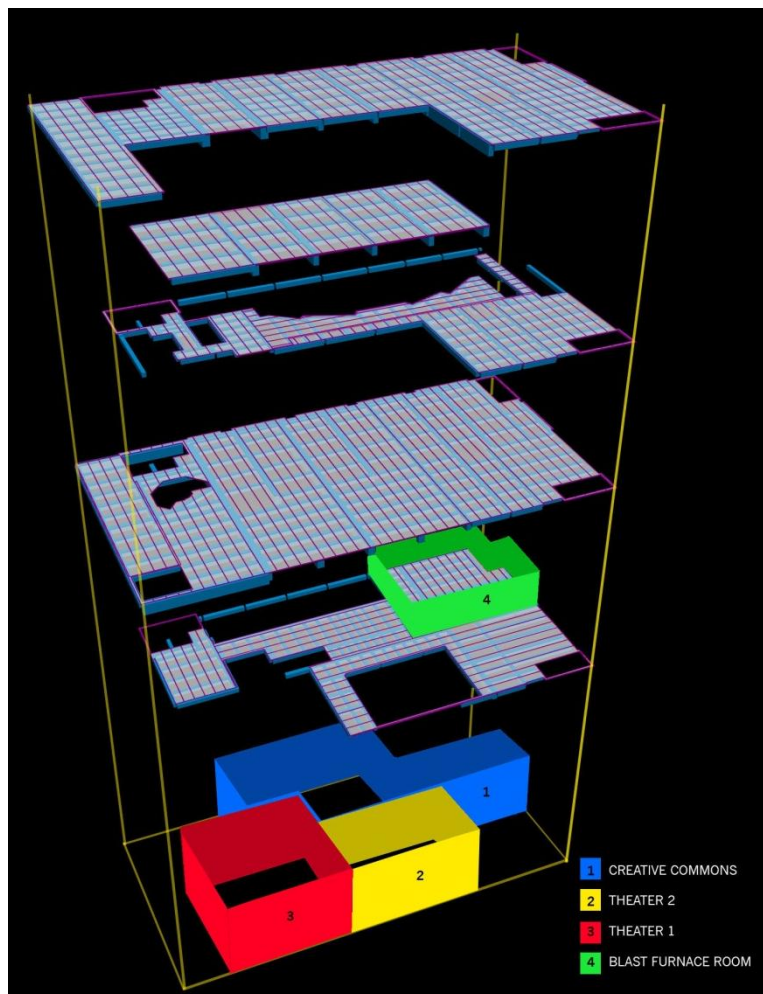

Figure 34: Spaces considered in acoustic analysis highlighted

As stated above, Reverberation Time (RT) evaluates the sound decay within a space. For a space to be considered appropriately reverberant, acceptable conditions for each space were chosen based on the bar graph shown in Appendix G. Rooms where surface materials changed from the existing design were reevaluated for performance and the room criteria set in the initial design phase. The spaces considered for this evaluation include the Blast Furnace Room, both Theaters, and the Creative Commons, as highlighted in Figure 34.

The reverberation time for each existing space was evaluated based on the current room materials and compared to the redesign with the new structural system and without any further acoustical attenuation. Comparing this analysis with the design targets, further acoustical considerations were made to ensure the redesign met the RT set points for each space. This is further discussed below.

## Blast Furnace Room

The goal for this multipurpose room on the second floor in terms of the RT is in the range of 0.7-1.0 seconds, which allows for primarily speech, with potential for music use. Originally, this was a fairly dead space, and therefore, a slightly more 'live' room is allowable, as it allows for more variation in the space use. Table 22 displays the RT results for both the existing and the redesigned space.

**Table 22:** Reverberation times for the Blast Furnace Room

Comparison of Reverberation Times: Blast Furnace Room							
Frequency (Hz)		125	250	500	1000	2000	4000
Existing							
<i>Calculated Reverberation Time (s)</i>	RT =	0.78	0.60	0.51	0.55	0.50	0.52
Mid range average Reverberation Time				0.52			
Redesign							
<i>Calculated Reverberation Time (s)</i>	RT =	0.77	0.61	0.57	0.63	0.58	0.59
Mid range average Reverberation Time				0.59			

By eliminating the acoustic panels where painted concrete will now be located, this design will be more cost effective, as fewer panels will be required. Also, with the improvement in the space acoustics, the Blast Furnace Room is now a higher quality space for a reduced material cost. Yet, this does not fit within the desired RT range, even though it is a more successful design. It is suggested to continue investigation of space materials to obtain a higher RT value for the space.

## Theater 1 & Theater 2

The RT range for each of these theaters on the first floor is in the range of 1.0-1.2 seconds, which creates a more live or reverberant space, and is ideal for spaces like theaters and music halls. The goal for this redesign was to evaluate the impact of an unpainted concrete, as opposed to a painted concrete, as well as changes in the square foot of carpet. Table 23 and Table 24 display the RT results for both the existing and the redesigned space.

**Table 23:** Reverberation times for Theater 1

Comparison of Reverberation Times: Theater 1							
Frequency (Hz)		125	250	500	1000	2000	4000
Existing							
<i>Calculated Reverberation Time (s)</i>	RT =	1.00	0.40	0.34	0.35	0.32	0.33
Mid range average Reverberation Time				0.34			
Redesign							
<i>Calculated Reverberation Time (s)</i>	RT =	0.85	0.34	0.31	0.32	0.28	0.31
Mid range average Reverberation Time				0.30			

Table 24: Reverberation times for Theater 2

Comparison of Reverberation Times: Theater 2							
Frequency (Hz)		125	250	500	1000	2000	4000
Existing							
<i>Calculated Reverberation Time (s)</i>	RT =	1.08	0.41	0.35	0.36	0.33	0.33
Mid range average Reverberation Time				0.34			
Redesign							
<i>Calculated Reverberation Time (s)</i>	RT =	0.91	0.34	0.31	0.32	0.28	0.31
Mid range average Reverberation Time				0.31			

These results and the iterations behind them prove that both of these theater spaces designed to be very dead spaces. Generally, a cinema relies on the RT of the space for sound performance. This space, upon further investigation, relies on the sound system for acoustic performance, so a dead space is desired. The new system consequently, is adequate. Therefore, the theaters should not be redesigned for acoustic materials, and impact from the concrete redesign is negligible.

### Creative Commons

This common space and atrium area has a goal RT of 0.8 – 1.0 seconds, which allows for a controlled reverberation to ensure clarity in sound patterns. With adjoining spaces, such as the Blast Furnace Room, lobby, and quieter seating area, a slightly deader space is allowable. Table 25 displays the RT results for both the existing and the redesigned space.

Table 25: Reverberation times for the Creative Commons

Comparison of Reverberation Times: Creative Commons							
Frequency (Hz)		125	250	500	1000	2000	4000
Existing							
<i>Calculated Reverberation Time (s)</i>	RT =	1.01	1.69	2.19	2.30	2.29	1.86
Mid range average Reverberation Time				2.26			
Redesign							
<i>Calculated Reverberation Time (s)</i>	RT =	0.60	0.60	0.91	1.01	0.74	1.04
Mid range average Reverberation Time				0.89			

By replacing the existing steel system with concrete, this space results in a higher mid-frequency RT value, of 0.89 seconds as compared to 0.56 seconds, which is more appropriately within the range of desired RT values for this space, than high above this range. Therefore, this space is a successful redesign and does not require additional acoustic material design.

### 3.2 Sound Transmission Criteria

A higher Sound Transmission Criteria (STC) value, a rating that approximates the Transmission Loss of a material, results in a more efficient design that reduces sound transmission. With floor systems being altered, primary spaces were evaluated for the acoustic development of the floor system. Target STC values were chosen based on acoustic requirements of each space based upon that space's requirements and the type of adjacent space.

Looking at the interaction between different spaces, it is noted that the Creative Lobby/Blast Furnace Room on the second floor and the Musikfest Café on the third floor have a floor system acoustically designed between them as a sound barrier. Therefore this flooring, as it will change, will impact the sound transmission between these two spaces.

The existing flooring consists of two different systems. Above the Creative Commons is an 8" concrete slab and metal decking system. Above the Blast Furnace Room, a more sound isolated space, the 8" of concrete and metal decking also includes acoustical ceiling tile. The new system, proposed as a 6" slab, and a 6" slab with acoustical ceiling tile, respectively, is being evaluated for effectiveness by use of the STC values.

A plan of the third and second floor overlaid is seen in Figure 35. A cross section of these two floor systems and their corresponding STC requirements can be seen in Figure 36.

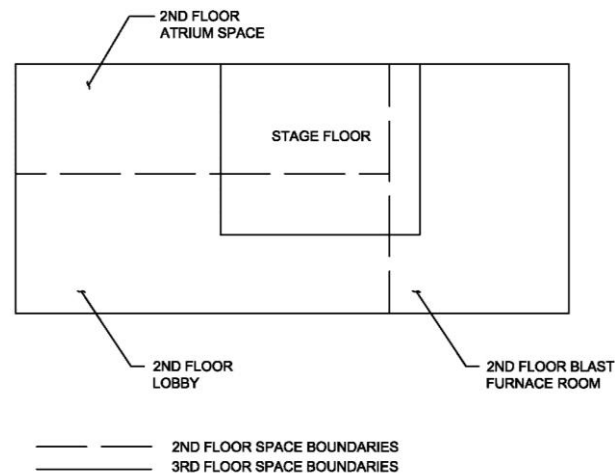

Figure 35: Second & third floor overlay

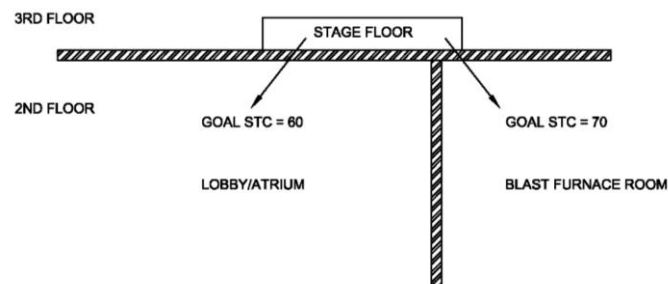
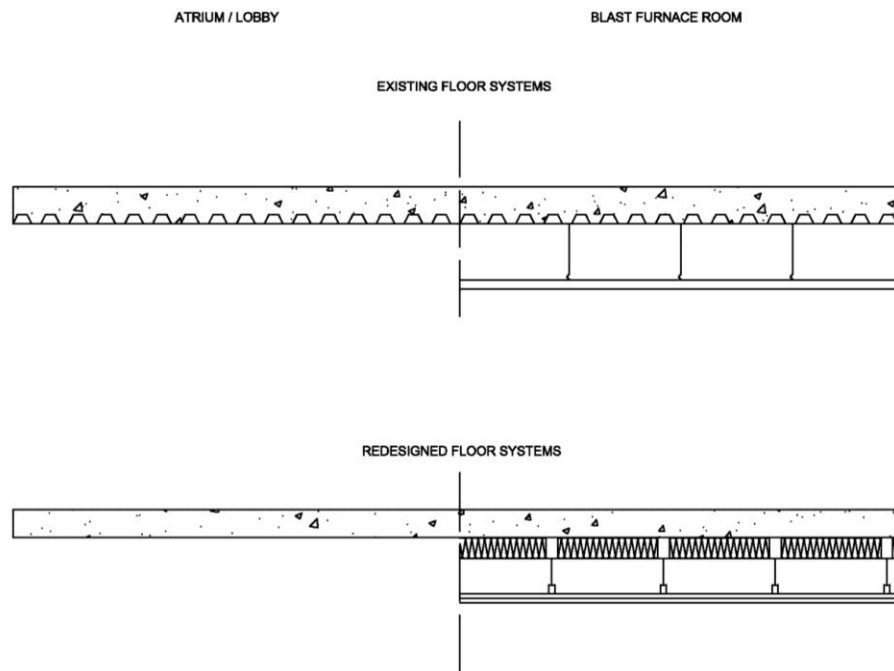

Figure 36: Section showing STC values



**Figure 37:** Floor composition options

Data is available only for a portion of floor cross sections, and therefore, the cross section used for the existing can be modeled as (a) an 8" slab and decking system and (b) an 8" slab and decking system hanging acoustical ceiling tile. These systems were redesigned as (c) a 6" concrete slab and (d) a 6" concrete slab with 3/8" plywood, 2 layers of gypsum wallboard, and 2" kinetics isolators. Each of these systems can be seen in Figure 37.

As can be seen in the STC graph in Figure 38 for the system spanning between the Creative Commons and Musikfest Café, the new structural floor system is above the existing and is therefore sufficient. For the other space, which is being redesigned with a thinner floor slab, no metal decking, and continued acoustical ceiling tiles, it is realized that the system is still sufficient. As can be seen in Figure 39, the STC Contour from this design results in 84 dB, which is higher than the existing 58 dB and above the desired 70 dB for this floor system.



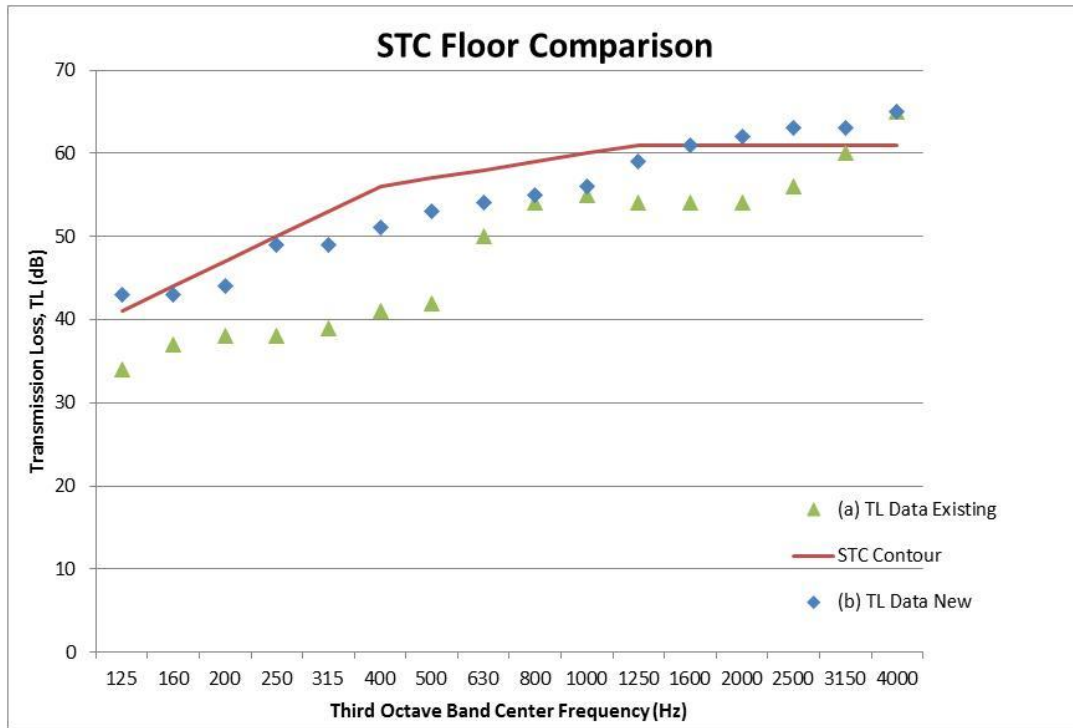

Figure 38: Comparison for Creative Commons and Musikfest Cafe

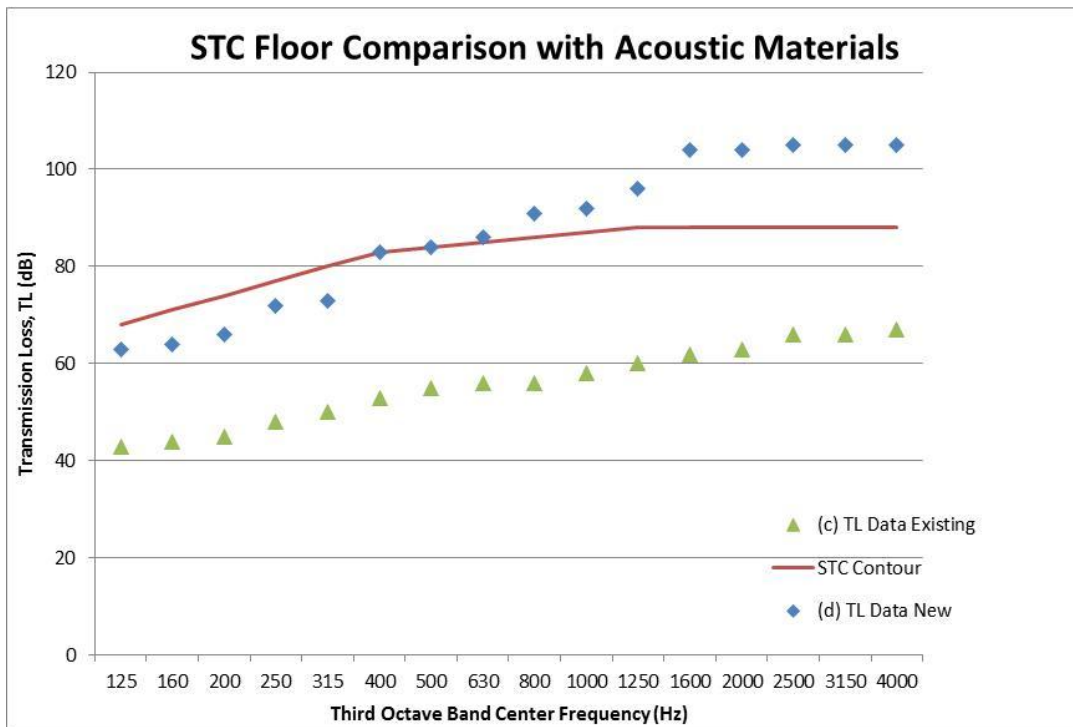

Figure 39: Comparison for Creative Commons and Blast Furnace Room

**Table 26:** Cost comparison of floor systems

Cost Comparison		
System		Total Cost per sq.ft.
5" slab & decking	EXISTING	10.16
6" concrete slab	REDESIGN	10.88
5" slab & decking w/ acoustic ceiling	EXISTING	15.18
6" concrete slab w/ spring isolators and acoustic ceiling	REDESIGN	15.21

After confirming the new design is acoustically sufficient, a cost comparison was done, per square foot, to estimate the monetary impact of the redesign as compared to the existing. As can be seen in Table 26, the redesigned system costs are comparable to the existing floor system. Though the new system costs 6% more for the simpler system, the floor system above the Blast Furnace Room is a competitive cost per square foot. Therefore, the structural redesign, with the addition of the necessary acoustic materials, is efficient and suggested as the appropriate design for the floor system in terms of both acoustics and cost with a concrete redesign.

## Conclusions

In the reevaluation of the RT of each space, surface materials were evaluated and changed based on performance of the spaces. The Blast Furnace room resulted in a better performance, though the RT is still below the desired range. Further investigation of alternative materials is suggestive for a higher RT time. Both theater spaces were matched, and perform adequately. The Creative Commons were much improved for a lively space that does not allow for an abundance of echo.

In evaluation of the new floor material between the Musikfest Café and the spaces below, the floor system was matched to the performance of the existing system. This resulted in a slightly higher cost, due to the structural materials, though additional acoustic materials were eliminated.

## Chapter 4: Breadth II: Architecture

Altering the building material from structural steel to a cast-in-place concrete system will directly impact the architecture of the SSPAC. This section will consider the impacts of the redesign on multiple interior spaces, looking at the impacts and adjusting accordingly. For each space, an image of the existing and a rendering of the redesign will be compared and the impacts briefly discussed. These spaces are:

The Creative Commons – first and second floor lobby & atrium

The Blast Furnace Room – second floor multipurpose room

While the building aesthetics change drastically, the building circulation is not majorly impacted. Even though the columns will be slightly larger than the existing steel, most are included in wall lines, and do not directly impact the spaces. The redesign considered this and maintained current building circulation. More of the impacts on each individual space are considered below.

### 4.1 Creative Commons

The Creative Commons is an interactive, open space spanning the first and second floor that was designed with the intent of displaying clear cuts and structural details, as well as highlighting the iconic orange color of the manufactured products of the original site. The original space can be seen in Figure 41, with the redesign seen in Figure 42. The camera view used on both images is seen in Figure 40.

This use of exposed steel also created a dialogue between some of the existing surrounding unused steel-mill buildings and the interior of the spaces. Through the constant rhythm created by the concrete beams, the perspective of the space and relation to it are kept. The initial design focuses on a compressed space opening into a larger one, and this is maintained through a redesign goal of a higher architectural ceiling. While the original space brought the outside into the space, the use of concrete creates a more secure envelope while still interacting with the exterior. Columns will be designed to not obstruct views within the space. These structural members create a more solid space, and maintain a similar rhythm to the existing steel, through a less busy, consistent beam and girder layout. Similar to the existing system, the final redesign included these exposed structural members as painted orange and accented with lighting.

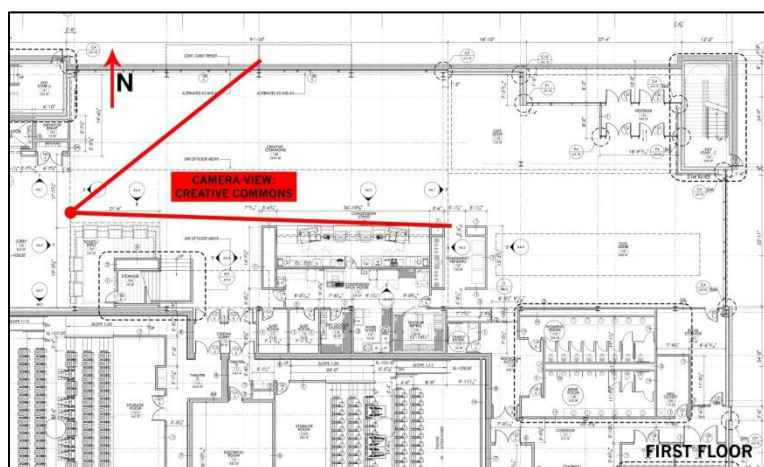

Figure 40: Camera view for Creative Commons



Figure 41: Existing Creative Commons space



Figure 42: Redesigned Creative Commons space

## 4.2 Blast Furnace Room

The Blast Furnace Room, located on the second floor of the SSPAC, is being viewed from the south east corner of the room, as can be seen in the camera view in Figure 43. The existing space, as seen in Figure 44, is being compared to the redesigned system, as seen in Figure 45. As originally designed, this room looks out towards the surrounding blast furnaces and has large trusses spanning across the room, highlighted by the orange color and focused lighting.

The change from trusses to deep concrete members is the primary impact on the architecture in the Blast Furnace Room. Trusses allow for a more spacious look, and are highlighted in the existing system by lighting and orange accent paint. With a concrete system, these structural members create a bolder, understandable space. To make this similar to the existing system, the final redesign included these exposed structural members as painted orange and accented with lighting, similar to the existing room. This also allows the room to take focus off of the trusses and be visually cleaner. With the concrete beams not taking as much focus, more can be driven towards the interaction of the room with the spaces outside – the blast furnaces, atrium, and second floor that adjoin this space.

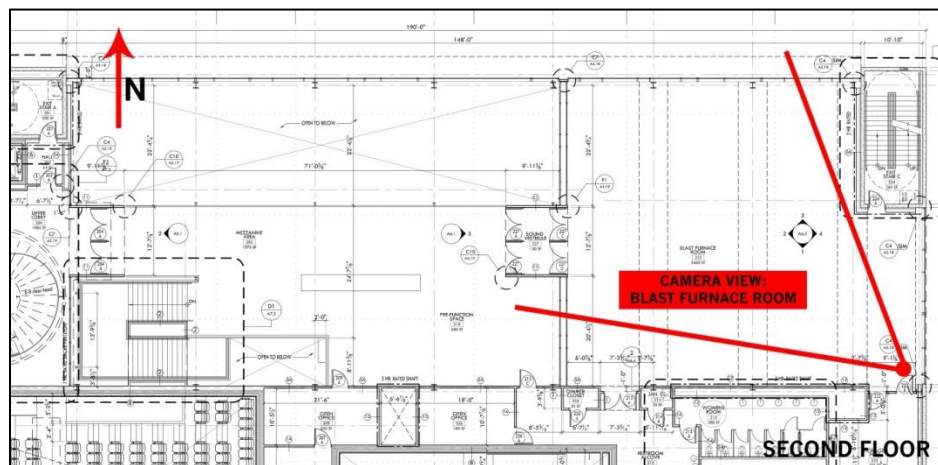

Figure 43: Camera view for Blast Furnace Room



Figure 44: Existing Blast Furnace Room space



Figure 45: Redesigned Blast Furnace Room space

## Chapter 5: Conclusion

The SSPAC was redesigned as a cast-in-place concrete gravity and lateral system. Through this design process following ACI 318-11, it can be seen that concrete is a plausible system with some architectural adjustments in certain areas, with seen benefits to some of the current architectural features.

For the gravity design, a bay from each floor was fully designed, with both a normal weight typical reinforced one-way slab-and-beam system and a prestressed system. This analysis resulted in the decision to use prestressed systems for the larger spanning bays. Typical columns, gravity walls, and foundations were successfully designed according to this controlling design. This design gave a better understanding to the design process and specific benefits and disadvantages to the corresponding systems, the computer modeling process, and associated rule-of-thumbs and was overall a success.

The lateral system was also redesigned as an entirely shear system. This redesign took advantage of the redesigned concrete gravity system, and was a successful design. Compared to the existing dual system utilizing braced frames and cast-in-place shear walls, this system takes a more integrated approach with the gravity system and therefore has less redundancy, even though both take advantage of the resources already being used for construction.

The use of a concrete system is beneficial in relation to the complex building layout and the flexibility of concrete to fit different floor diaphragm configurations. Locations where large cantilevers and open spaces were required and floor-to-floor height was desire, prestressed concrete was found to be a viable option. Steel though, was found to be more beneficial in terms of construction and cost and in places where hanging columns were utilized. These would be possible in concrete, but an altering of the current system would be required to be beneficial.

These structural redesigns also impacted other aspects of the building design and construction process. The first one considered in this thesis was the impact on the acoustic performance of each of the spaces, as appropriate for the building use. Reverberation time and sound transmission were evaluated. Concrete design resulted in better acoustic performance in terms of sound isolation and allowed for minimizing acoustic paneling in some rooms when analyzing them for reverberation time.

The architecture was also impacted and considered throughout the redesign process. Room layouts and space uses were not altered by additional columns or layout changes. Two of these spaces were further considered for architectural impact and adjusted as necessary. These analyses were successfully in maintaining the space and atmosphere first created.

In conclusion, the redesign of the SteelStacks Performing Arts Center structural system and evaluation of this redesign's impact on the acoustics and architecture was a success. The proposed thesis goals were exceeded both in depth and breadth, and provided ample knowledge into the design process of concrete and steel systems, as well as the details of prestressed systems, acoustics, and architectural impacts.

## References

ACI 318-11. Farmington Hills, MI: American Concrete Institute, 2011.

ASCE 7-05. Reston, VA: American Society of Civil Engineers, 2006. Print.

Company, Kingston, MA Waier, P. R., ed. (2012). RS Means Building Construction Cost Data 2012, 69th ed., RS Means.

Egan, M. David. Architectural Acoustics. New York: McGraw-Hill, 2007. Print.

Lepage, Dr. Andres. "Advanced Computer Modeling." AE 530 – Advanced Computer Modeling. The Pennsylvania State University, University Park. 2012. Lecture.

Lepage, Dr. Andres. "Advanced Concrete Design for Buildings." AE 431 – Advanced Concrete Design for Buildings. The Pennsylvania State University, University Park. 2012. Lecture.

Lepage, Dr. Andres. "Design of Concrete Structures for Buildings." AE 402 – Design of Concrete Structures for Buildings. The Pennsylvania State University, University Park. 2012. Lecture.

Nawy, Edward G. *Prestressed Concrete: A Fundamental Approach*. Upper Saddle River, NJ: Pearson Prentice Hall, 2010. Print.

RAM Manager. Bentley Systems, Incorporated, 2012. Print.

Schneider, Walter. "Geotechnical Engineering for AE Majors." CE 397A – Geotechnical Engineering for AE Majors. The Pennsylvania State University, University Park. 2012. Lecture.

Wight, James, and James MacGregor. *Reinforced Concrete Mechanics & Design*. Upper Saddle, NJ: Pearson Prentice Hall, 2008. Print.



## Appendix A Structural System Overview

### Site Plan Detail

The location of the existing site at onset of project with current location overlaid.

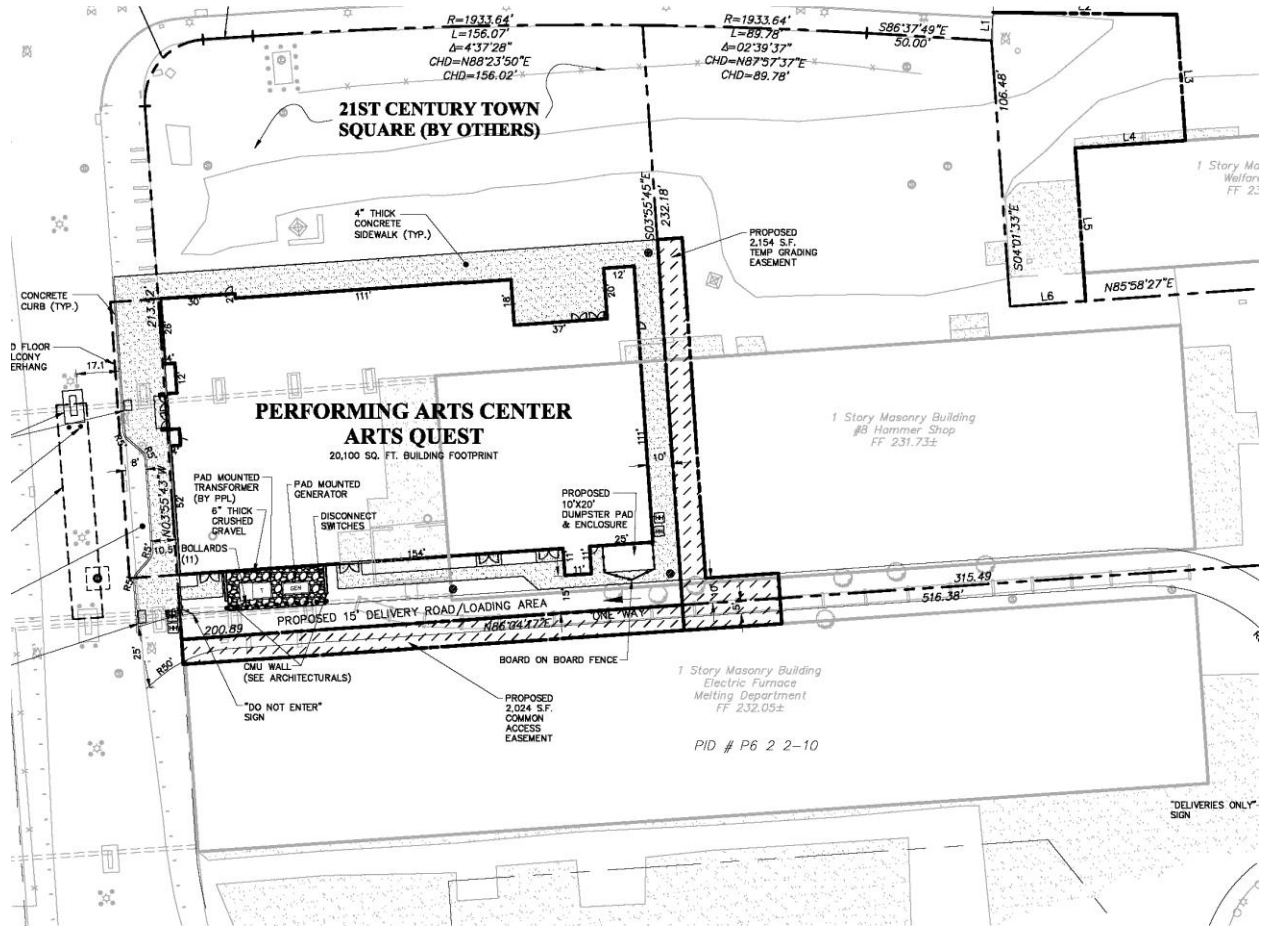

### Architectural Floor Plans

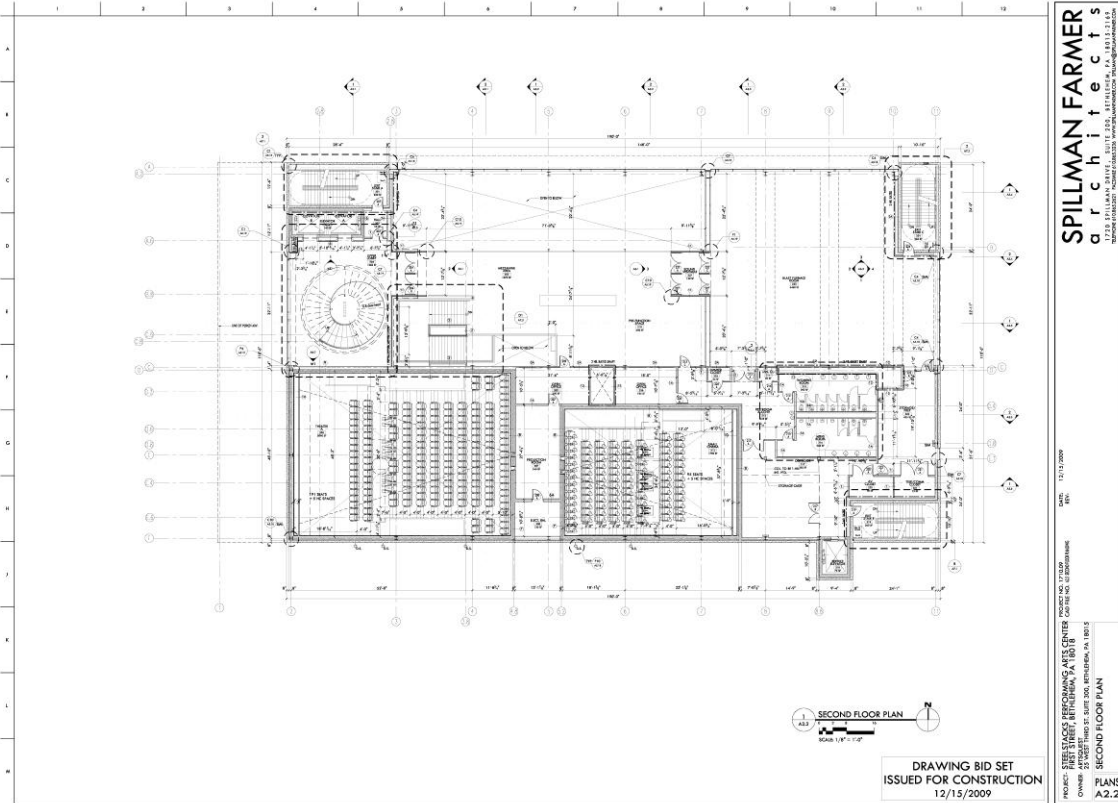
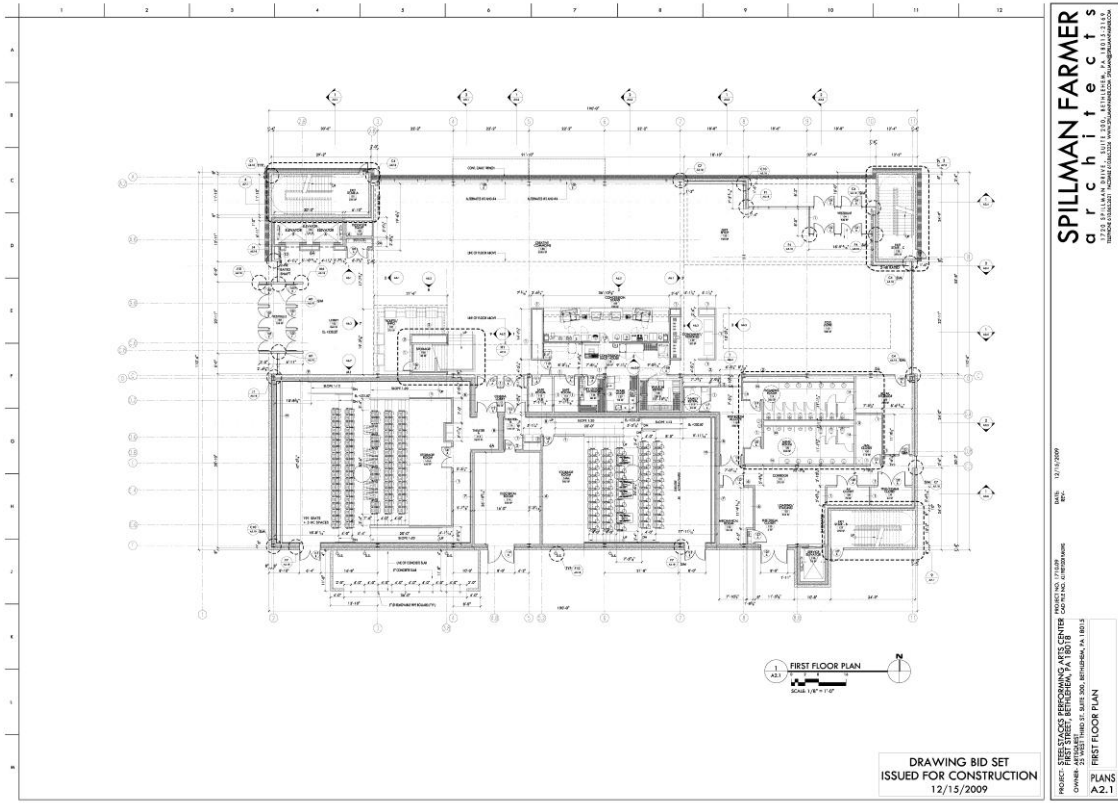

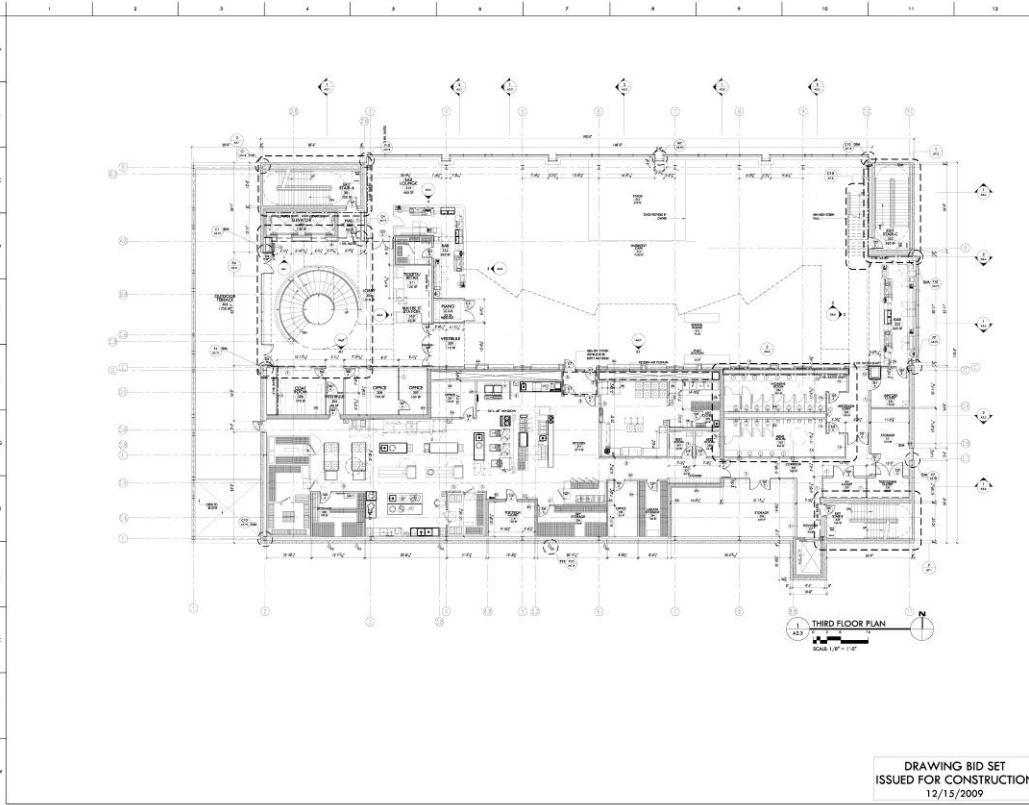

**SPILLMAN FARMER**  
a r c h i t e c t s  
1728 HILLMAN DRIVE, SUITE 200, METLICKA, PA 18122-2116  
PH: 610-261-1111 FAX: 610-261-1112  
WWW.SPILLMANFARMERARCHITECTS.COM

DATE: 12.15.2009  
DWG: 021

PROJECT: STEELSTACKS PERFORMING ARTS CENTER  
OWNER: STEELSTACKS PERFORMING ARTS CENTER  
25 WEST 12TH STREET, BETHLEHEM, PA 18018  
PROJECT LOCATION: BETHLEHEM, PA 18018

THIRD FLOOR PLAN  
PLANS  
A2.3

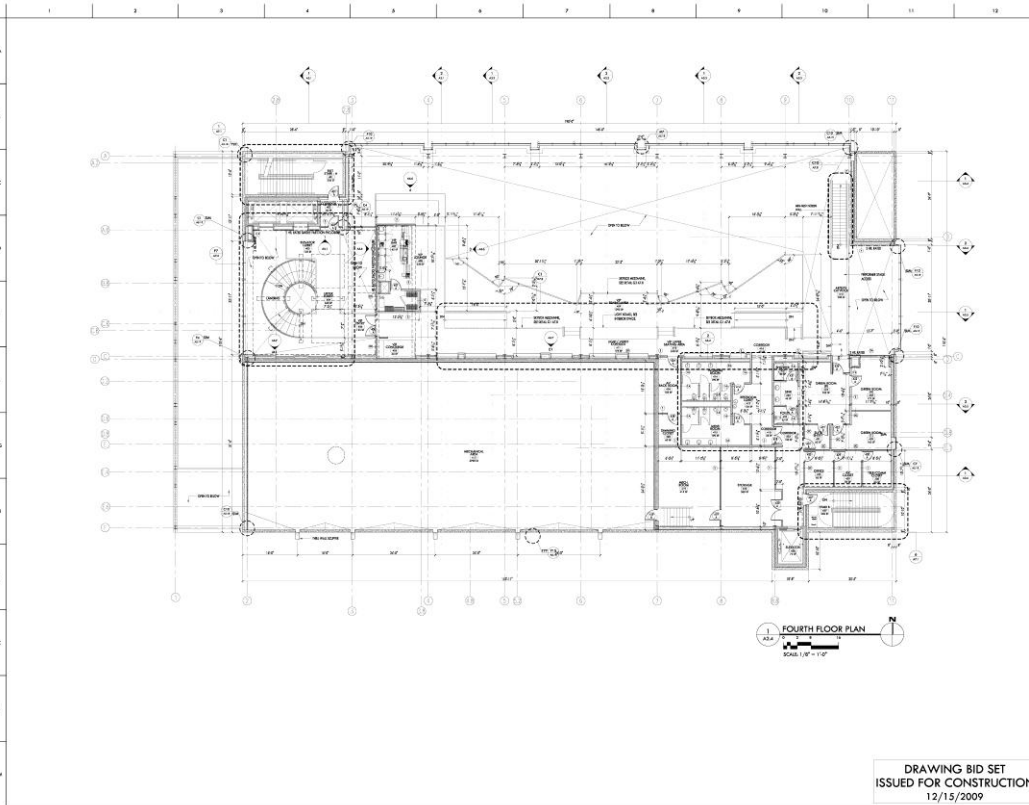

**SPILLMAN FARMER**  
a r c h i t e c t s  
1728 HILLMAN DRIVE, SUITE 200, METLICKA, PA 18122-2116  
PH: 610-261-1111 FAX: 610-261-1112  
WWW.SPILLMANFARMERARCHITECTS.COM

DATE: 12.15.2009  
DWG: 021

PROJECT: STEELSTACKS PERFORMING ARTS CENTER  
OWNER: STEELSTACKS PERFORMING ARTS CENTER  
25 WEST 12TH STREET, BETHLEHEM, PA 18018  
PROJECT LOCATION: BETHLEHEM, PA 18018

FOURTH FLOOR PLAN  
PLANS  
A2.4

Structural Floor Plans

**SPILLMAN FARMER**  
a r c h i t e c t s  
1720 SPILLMAN DRIVE, SUITE 200, BETHLEHEM, PA 18015-2169  
TEL: 610.661.5211 FAX: 610.661.5212 WWW.SPILLMANFARMER.COM

**Barry Bell & Associates, Inc.**  
Consulting Engineers & Surveyors  
1880 39th Street  
Trenton, PA 18677-0477  
www.barrybell.com

PROJECT NO. 1056008.A00  
DATE: 10/02/09  
REV: 11/05/09  
REF: 3/10/09  
3/12/09

PROJECT: STEELSTACKS PERFORMING ARTS CENTER  
OWNER: 101 FOUNDERS WAY, BETHLEHEM, PA 18018  
ARCHITECT: SPILLMAN FARMER ARCHITECTS  
CONTRACTOR: BETHLEHEM STEEL INDUSTRIES  
PROFESSIONAL SEAL AFFIXED  
DRAWING NO. 1056008.A00  
COPYRIGHT 2009 SPW

**SECOND FLOOR FRAMING PLAN**  
\$2.0

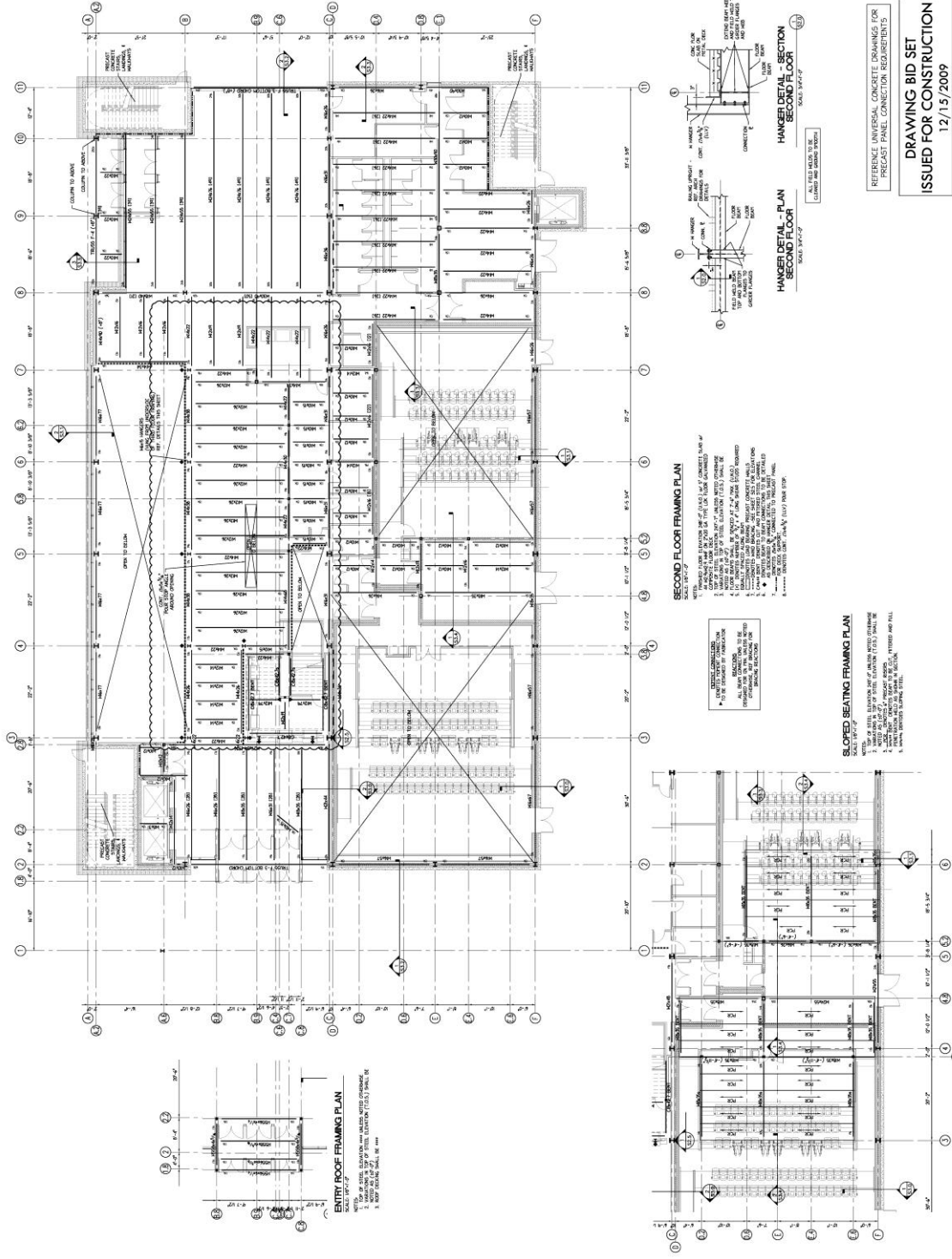

Lateral System

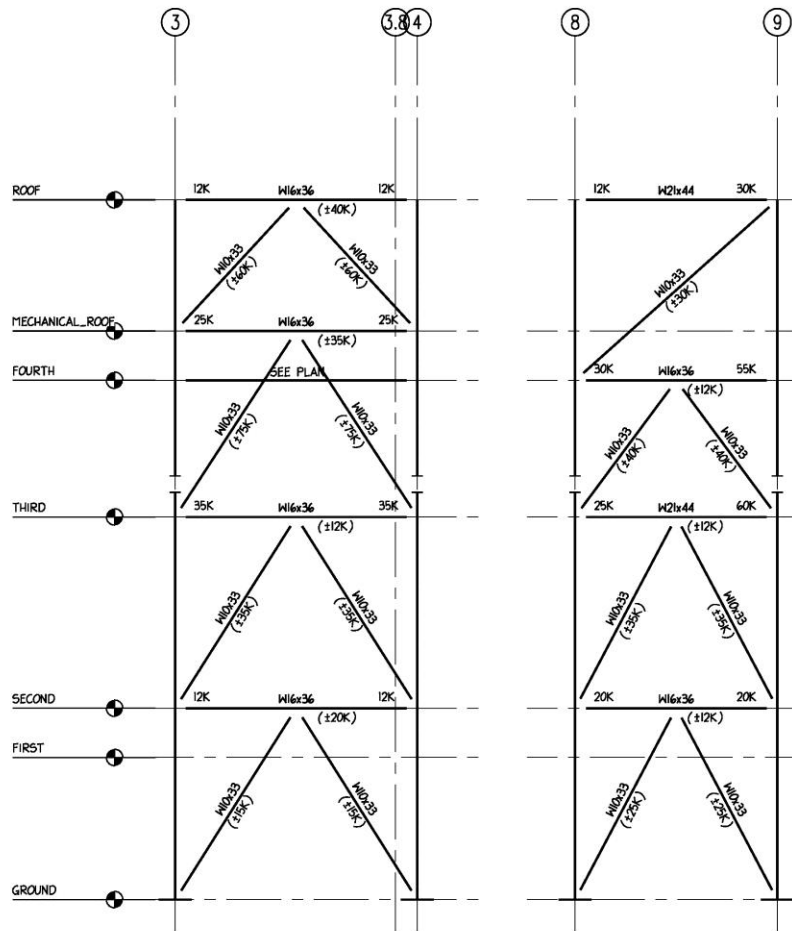

1 ELEVATION AT LINE C  
SCALE: 1/8"=1'-0"

- NOTES:
1. CONNECTIONS TO BE DESIGNED FOR FORCES INDICATED BY FABRICATORS ENGINEER.
  2. (\*\*K) DENOTES AXIAL FORCE IN MEMBER  
(+) TENSION  
(-) COMPRESSION
  3. \*\*K DENOTES VERTICAL REACTION ON END OF BEAM

## Appendix B Existing: Wind Calculations

Sarah Bednarcik	WIND LOAD CALCS	THESIS Sept 2012
-----------------	-----------------	------------------

11

USING: Chapter 6: Wind Loads ASCE 7-05  
Method 2:

Bldg layout:

all units in feet

ROOF height = 64'0"

Simplified:

Lower roof height at 51'6" is surrounded by parapet, which goes to 64'0" elevation. Because this space is about 25% of the total roof sq. ft. To simplify this calculation, this is considered at elevation 64'0". Thus, the roof is a flat roof at 64'0" with no parapet.  
∴ mean roof height,  $h = 64'$

For a N-S wind:

$L = 111 \text{ ft}$

$B = 140$

For an E-W wind:

$L = 140 \text{ ft}$

$B = 111 \text{ ft}$

6.5.3 Design (Values) Procedure

1. Wind Speed  $V = 90 \text{ mph}$  (Figure 6-1)
- Directionality Factor  $K_d = .85$  (Table 6-4)
2. Importance factor,  $I = 1.15$  (Table 6-1)
- Category III (by Table 1-1)
3. Exposure Category:
  - by Section 6.5.6. - Surface Roughness B. → Exposure B
  - Velocity Pressure Exp. Coeff (Table 6-3)
  - Case 2, Exp B.
  - interpolate  $z = 60 \begin{cases} .85 \\ .89 \end{cases} \rightarrow \text{at } z = 64 \quad K_z = .87$
  - $z = 70 \begin{cases} .85 \\ .89 \end{cases}$
4. Topographic factor,  $K_{zt}$ 
  - by Section 6.5.7  $K_{zt} = 1.0$
5. Gust effect factor  $G$  or  $G_f$ 
  - by Section 6.5.8
  - rigid or flexible.
  - $n_1 = \frac{100}{64} = 1.56$       C6-17
  - $n_1 = \frac{75}{64} = 1.17$       C6-18

∴ treat as a rigid system. (follow § 6.5.8.2)

RIGID

2/2

$$G = .925 \left( \frac{1 + 1.7 g_v \bar{I}_z \bar{Q}}{1 + 1.7 g_v \bar{I}_z} \right)$$

$g_Q = g_v = 3.4$

from Table 6-2  $\alpha = 7.0$   $Z_g = 1200$   $Z = 1/4.0$   $\bar{G} = 0.45$   
 $C = 0.3$   $r = 320$   $r = 320$   $\bar{E} = 1/3.0$

$\bar{I}_z = 0 \left( \frac{35}{2} \right)^{1/6} = 0.30 \left( \frac{33}{38.4} \right)^{1/6} = .293$   $\bar{Z}_{max} = \frac{6(64)}{30} = 38.4'$

$$Q = \sqrt{\frac{1}{1 + .63 \left( \frac{B+h}{\bar{I}_z} \right)^{.63}}} = \sqrt{\frac{1}{1 + .63 \left( \frac{B+64}{336.6} \right)^{.63}}}$$

N-S  $B = 190$  ft

$B = 111$  ft

E-W

$\therefore Q = .877$

$\therefore Q = .910$

$$G = .925 \left( \frac{1 + 1.7(3.4)(.293)(.877)}{1 + 1.7(3.4)(.293)} \right) = .853$$

$$= .925 \left( \frac{1 + 1.7(3.4)(.293)(.910)}{1 + 1.7(3.4)(.293)} \right) = .873$$

6. enclosure - fully enclosed

7. internal pressure,  $G C_{pi} = \pm 0.18$

by Fig. 6-5

8. ext pressure coeffs.

Fig 6-6 walls: windward

$C_p = .80$

leeward

$C_p = -.5$

N-S  $L/B = 111/190 = .584$   $\rightarrow$

$C_p = -.36$

E-W  $L/B = 190/111 = 1.71$   $\rightarrow$

$C_p = -.70$

(interpolated)

Side

roof:

$\theta = 0^\circ$   
 N-S  
 $.5 < h/L < 1.0$   
 $\therefore$  interpolate

-1.0  
 -0.8  
 -0.5  
 NA

0 to  $h/2$  -1  
 $h/2$  to  $h$  -1  
 $h$  to  $2h$  -1  
 $> 2h$  -1.3

$\theta = 0$   
 E-W  
 $h/L \leq .5$

Roof Area =  $190 \times 111 > 1000$  SF  
 $\therefore$  Reduction factor = .9

9. velocity pressure  $q_z$  at  $h = 64'$

$\leq 6.5.10$

$q_z = .00256 K_z K_{zt} K_d V^2 I = 17.63$  - others on excel spreadsheet

10. MWFRS:

$P = q G C_p - q_i (G C_{pi})$

pressure:

$P = q_h G C_p - q_z G C_{pi}$

where  $q = q_z$  for windward. All else  $q = q_h$ .

See excel for further calcs.

Overturning Moment/Base Shear North-South Direction														
Location	Height	Area Below (ft <sup>2</sup> )	Area Above (ft <sup>2</sup> )	Pressure Below (psf)	Pressure Above (psf)	Factored Story Load (k) Windward	Pressure Below (psf)	Pressure Above (psf)	Factored Story Load (k) Leeward	Factored Story Shear (k)	Overturning Moment (k-ft)	Factored Story Load	Width (ft)	
Roof	64	1662.5	0	8.45	8.86	22.48	-10.69	-10.69	-28.44	50.93	3259	50.93		
Floor 4	46.5	1187.5	1662.5	7.43	8.45	36.61	-10.69	-10.69	-48.76	136.29	3969	85.37		
Floor 3	35	1662.5	1187.5	6.11	7.43	30.38	-10.69	-10.69	-48.76	215.43	2770	79.14		
Floor 2	17.5	1662.5	1662.5	5.80	6.11	31.69	-10.69	-10.69	-56.88	304.00	1550	88.58		
Ground	0	0	1662.5	0	5.80	15.44	0	-10.69	-28.44	347.89	0	43.88		
						Factored Total Base Shear (k):							11549	
Overturning Moment/Base Shear East-West Direction														
Location	Height	Area Below (ft <sup>2</sup> )	Area Above (ft <sup>2</sup> )	Pressure Below (psf)	Pressure Above (psf)	Factored Story Load (k) Windward	Pressure Below (psf)	Pressure Above (psf)	Factored Story Load (k) Leeward	Factored Story Shear (k)	Overturning Moment (k-ft)	Factored Story Load	Width (ft)	
Roof	64	971.25	0	8.72	9.14	13.55	-8.71	-8.71	-13.54	27.09	1734	27.09		
Floor 4	46.5	638.25	971.25	7.67	8.72	21.39	-8.71	-8.71	-22.44	70.92	2038	43.83		
Floor 3	35	971.25	638.25	6.30	7.67	17.63	-8.71	-8.71	-22.44	110.99	1402	40.07		
Floor 2	17.5	971.25	971.25	5.21	6.30	17.89	-8.71	-8.71	-27.08	155.97	787	44.97		
Ground	0	0	971.25	0	5.21	8.09	0	-8.71	-13.54	177.60	0	21.64		
						Factored Total Base Shear (k):							5962	



## Appendix C Existing: Seismic Calculations

S Bednarcik	Seismic Calcs	T/B
Ch. 11 §11.4 Seismic Design Values	USING ASCE 7-05.	
$S_s = 0.162g$ $S_1 = 0.062g$	From Geotech Report	structure: • eccentrically braced steel frame in E-W • shear walls in N-S.
Site class D. SDC C Occ. Cate. IV	§11.4.2	
by table 11.4-1 table 11.4-2	$F_a = 1.6$ $F_v = 2.4$	
$S_{ms} = F_a \cdot S_s = 1.6 (0.162) = .4208$ $S_{m1} = F_v \cdot S_1 = 2.4 (0.062) = .1488$	$\rightarrow S_{DS} = \frac{2}{3} S_{ms} = .281$ $S_{D1} = \frac{2}{3} S_{m1} = .099$	
$S_a = S_{DS} (0.4 + 0.6 T/T_0)$ $T_0 = 0.2 S_{D1} / S_{DS} = .071$ $T_0 = S_{D1} / S_{DS} = .356$	$T_c = 6$ by Fig 12-15	
Finding $T_1$ fundamental period of bldg.		
$T_a = C_t h_n^x = 0.03 (64)^{.75} = .6788$	by T. 12.8-2	
$C_u = 1.7$	T. 12.8-1	
$T \leq C_u T_a = 1.7 (.6788) = 1.15$	< $T_c$ ✓ ok	
by 12.8.2, allowed to use $T_a$ .		
$C_s = \frac{S_{DS}}{R/I} = \frac{.281}{3/1.5} = .140$	← compare to engr's value = .139 ✓ good.	
$C_s = .139 \leq \frac{S_{D1}}{T(R/I)} = \frac{.099}{1.15(2)} = .042$	by § 12.8.1-1 (12.8-3) can use $C_s = .042$	
$V_s = C_s \cdot W$		
Calculate Bldg Weight.		

S Bednarcik	Seismic calcs	1B
Building weight §12.8.3		
<u>Floor 2,4</u>		
5' slab of deck	<ul style="list-style-type: none"> <li>• slab 50 PSF</li> <li>• MEP 7 PSF</li> <li>• framing 10 PSF</li> </ul>	67 PSF
<u>Floor 3</u>		
8" slab of deck	<ul style="list-style-type: none"> <li>• slab 87.5 PSF</li> <li>• MEP 7 PSF</li> <li>• framing 10 PSF</li> </ul>	105 PSF
<u>Roof</u>		
Lt wt conc 5"	<ul style="list-style-type: none"> <li>• snow 30 PSF</li> <li>• slab 40 PSF</li> <li>• MEP 10 PSF</li> </ul>	80 PSF
<u>Mech Roof</u>		
5" slab of deck	<ul style="list-style-type: none"> <li>• slab 50 PSF</li> <li>• MEP* 20 PSF</li> <li>• framing 10 PSF</li> </ul>	80 PSF
		*takes into account rooftop units
PCF from AISI Table 17-13		
<u>Materials</u>		
cmu wall	8" thick = $(\frac{8}{12}) 137$ PCF = 92 PSF	
precast panels	8" thick = $(\frac{8}{12}) 150$ PCF = 100 PSF	
curtain wall system	glass w/ alum. mullions = 20 PSF	as per specs of manuf.
<u>Mechanical System</u>		
RTU	2400	ERU 1056
	1000	1536
	1350	1732
	10550	4285
	10625	8.6 K
	1400	
	27.3 k	
		total = 35.9 k
see excel for further calcs		

Weight of Building	Area	PSF	Load (lbs)	Story Weight (lbs)
<b>CMU</b>	4310	91	392210	
<b>Curtain Wall</b>	2160	20	43200	
<b>Concrete Panels</b>	9610	100	961000	
<b>Floor 2</b>	12090	67	810030	2206440
<b>CMU</b>	9140	91	831740	
<b>Curtain Wall</b>	2160	20	43200	
<b>Concrete Panels</b>	9610	100	961000	
<b>Floor 3</b>	21060	105	2211300	4047240
<b>CMU</b>	5920	91	538720	
<b>Curtain Wall</b>	2300	20	46000	
<b>Concrete Panels</b>	6030	100	603000	
<b>Floor 4</b>	21060	67	1411020	2598740
<b>Mechanical (RTU)</b>			35934	35934
<b>CMU</b>	4520	91	411320	
<b>Curtain Wall</b>	3500	20	70000	
<b>Concrete Panels</b>	8530	100	853000	
<b>Roof</b>	17460	80	1396800	2731120
<b>Columns</b>	1870	70	130900	130900
<b>Total Weight (lbs)</b>				11750374
				<b>(k)</b>
				11750

## Appendix D Gravity Redesign

### RC System

Hand Calculations:

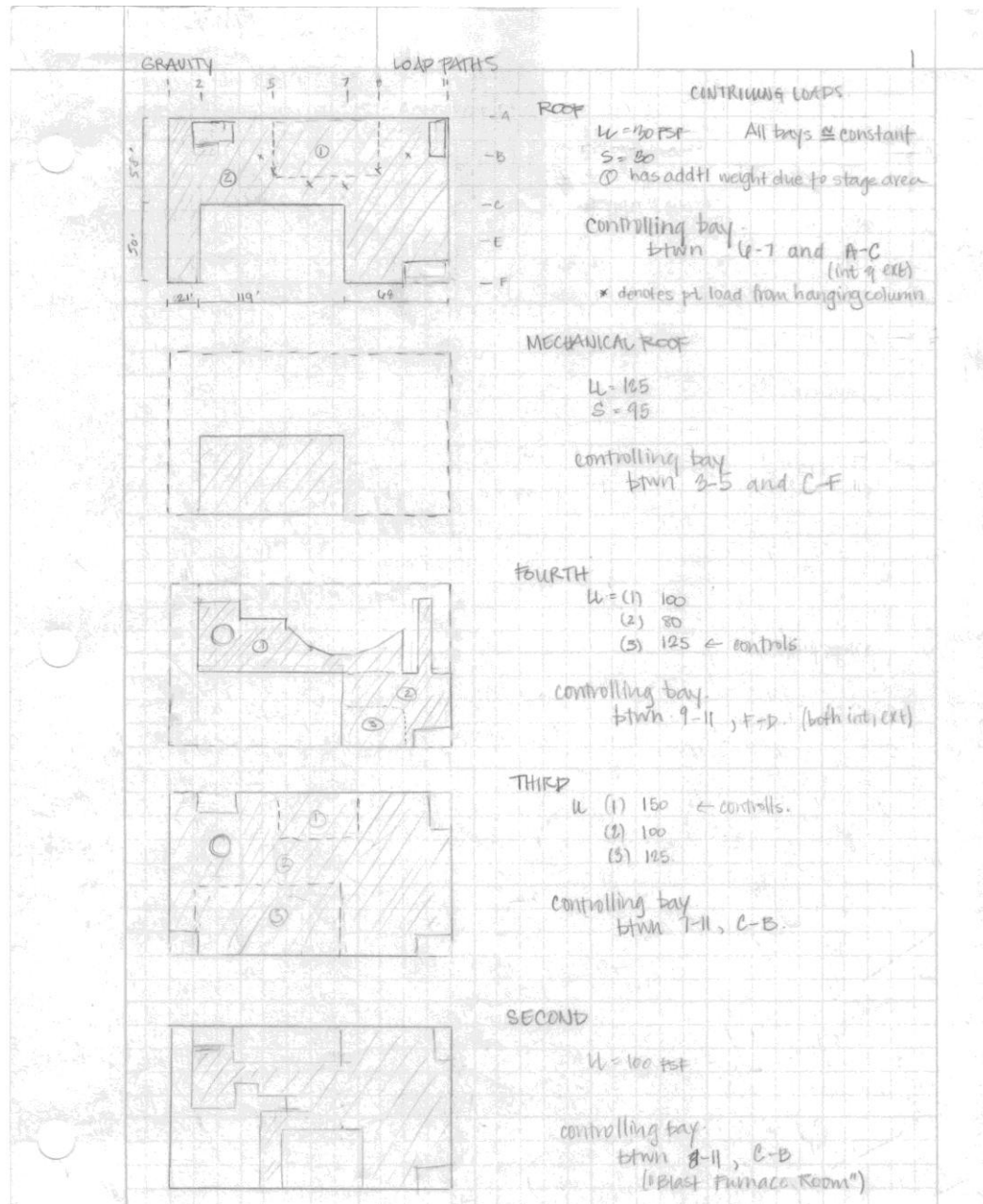

2

MECH ROOF

$W = 125 \text{ PSF}$

$f'_c = 4000 \text{ psi}$   
 $f_y = 60 \text{ ksi}$

Minimum slab thickness  $\frac{89.5}{14} = 6.4$

int. bay  $\frac{l}{29} = \frac{12'4" \times 16}{29} = 5.3"$

ext. bay  $\frac{l}{24} = \frac{12'4" \times 16}{24} = 6.2"$

use a slab thickness of 9"

$W_D = (9/12) (150 \text{ PCF}) = 107.5 \text{ PSF} + 20 \text{ Superimposed} = 107.5 \text{ PSF}$   
 $W_L = 125 \text{ PSF (Mech)}$

$W_u = 1.2(107.5) + 1.6(125) = 329 \text{ PSF}$

slab design:  
Assume tension controlled section  $\phi = 0.9$   
Beam width 12" (strip)  
 $W_u = 125 \text{ } \therefore 3(W_D) = 3(107.5) = 323 \text{ FOF}$  ✓ OK CAN USE ACI M. COEFF.

int bay:  $l = 12'5"$

$l_n = 13'7" = 11'5" = 11.42'$

$l_n \text{ avg} = 11'2" = 11.17'$

by 58.3

(A) First Int Sup.  
 $\frac{-wuln^2}{10} = \frac{-(329)(10.92)^2}{10} = -3923 \text{ lb-ft/ft width}$  controls

(B) Other int Sup.  
 $\frac{-wuln^2}{11} = \frac{-(329)(11.42)^2}{11} = -3900 \text{ lb-ft/ft width}$

(C) ext sup.  
 $\frac{-wuln^2}{24} = \frac{-(329)(10.92)^2}{24} = -1435 \text{ lb-ft/ft width}$

(D) Positive Mom: ext span  
 $\frac{+wuln^2}{11} = \frac{329(10.92)^2}{11} = +3900 \text{ lb-ft/ft width}$

(E) pos. Mom int span  
 $\frac{+wuln^2}{16} = \frac{329(11.42)^2}{16} = +2688 \text{ lb-ft/ft width}$

3

Reinforcement Assume  $\rho = 0.9d$  for int support

$$A_s = \frac{M_u}{\phi f_y (1 - \rho/2)} = \frac{M}{0.9 f_y \rho d} = \frac{-9923 \text{ lb-ft} \times 12''}{0.9 (60000) (0.9) (7.0)} = .14 \text{ in}^2/\text{ft width}$$

where  $d = h - c - db/2 = 8 - 1.5'' - .5(1.2) = 7.0''$

assume #4 bars  $db = .5$   $A_b = 0.20 \text{ in}^2$

$$a = \frac{A_s f_y}{\phi f_c b} = \frac{(.14)(60)}{.85(4)(12)} = .206$$

$$A_{s \text{ provd}} = .20 \text{ in}^2 > A_{s \text{ req'd}} = \frac{-9923 \times 12}{0.9(60000)(7 - .206(7))} = .13 \text{ in}^2 \quad \checkmark \text{OK}$$

$$\rho = \frac{A_s}{bd} = \frac{.13 \text{ in}^2}{(12)(7)} = .0015$$

by SPT § 7.12.  $\rho_{\text{min}} = .0018 \leftarrow \text{controls}$

Shear Check.

$$V_u = \frac{1.15 w_u l_n}{2} = \frac{1.15 (329)(10.92)}{2} = 2046 \text{ lb/ft of slab} \quad \text{ext face of 1st support}$$

$$V_u = \frac{w_u l_n}{2} = \frac{329(10.92)}{2} = 1796 \text{ lb/ft width} \quad \text{other supports}$$

$$\phi V_c = \phi 2 \sqrt{f_c} b_w d = 0.75(2) \sqrt{4000} (12)(7) = 7949 \text{ lb/ft} \gg V_u \quad \checkmark \text{OK}$$

Design Reinf

$$A_{s \text{ min}} = \frac{3 \sqrt{f_c} b_w d}{f_y} = \frac{3 \sqrt{4000} (12)(7)}{60000} = .27 \quad \leq 10.5.1 \text{ § 4}$$

$$A_{s \text{ min}} (\text{transverse}) = \rho b d = .0018 (12)(7) = .15 \quad \leq 7.12$$

$$A_{s \text{ min}} = 200 b_w d / f_y = 200(12)(7) / 60000 = .28 \text{ in}^2/\text{ft width}$$

Spacing

SPT  $S_{\text{min}} \begin{cases} 5h = 5(8) = 40 \\ 18 \leftarrow \text{controls} \end{cases}$

$S_{\text{max}} = \min \begin{cases} 3h = 24 \\ 18 \leftarrow \text{controls} \end{cases}$

$$S_{\text{max}} = \min \left\{ \begin{array}{l} 15 \left( \frac{40000}{f_s} \right) - 2.5c = 13.125 \\ 12 \left( \frac{40000}{f_s} \right) = 12'' \end{array} \right. \quad f_s = \frac{3}{4} f_y = 40 \text{ ksi}$$

$$S_{\text{min}} = 12''$$

here 8" slab  
#4 bars @ 8" o.c.  
#4 bars @ 12" o.c. transverse reinf.

	1st int sup
$I_n$	10.92
$M_u$	-9923
$A_{s \text{ req'd}}$	.13
$A_{s \text{ min}}$	.27
	.18
(trans)	.17
bars	#4 @ 8"
$A_{s \text{ provd}}$	.30 in <sup>2</sup>

others shown on following excel with calcs done using same method.

Slab Spreadsheet:

Input	Mechanical Roof			Roof			Roof			Fourth Floor		
	Exterior Support	Interior Support	Interior Span	Exterior Support	Interior Support	Interior Span	Exterior Support	Interior Support	Interior Span	Exterior Support	Interior Support	Interior Span
Minimum Slab thickness	8	12.4	12.4	6	11.64	11.64	6	11.64	11.64	6	11.64	11.64
Used Slab Thickness	12.4	10.92	10.92	11.64	10.14	10.14	11.64	10.64	10.64	11.64	10.1	10.1
Wu	125	329	329	30	138	138	30	138	138	125	290	290
Moment Coeff	-1/24	+1/11	-1/10	-1/24	+1/11	-1/10	-1/24	+1/16	-1/11	-1/24	+1/10	+1/16
Mu	1634.7	3566.6	3923.2	591.2	1289.9	1418.9	591.2	1289.9	1418.9	314.3	685.7	2144.8
As	0.058	0.126	0.138	0.029	0.064	0.070	0.029	0.064	0.070	0.016	0.034	0.106
As req'd	0.085	0.185	0.204	0.043	0.094	0.103	0.043	0.094	0.103	0.023	0.050	0.156
Shear	0.052	0.115	0.126	0.026	0.058	0.064	0.026	0.058	0.064	0.004	0.031	0.097
Vu (ext supports)	2066	--	--	805	--	--	805	--	--	850	--	--
phiVc	7969	1796	1879	5692	700	700	5692	734	734	5692	740	1247
OK?	OK	OK	OK	OK	OK	OK	OK	OK	OK	OK	OK	OK
Requirements	0.27	0.27	0.27	0.19	0.19	0.19	0.19	0.19	0.19	0.19	0.19	0.19
S&T	0.28	0.28	0.28	0.20	0.20	0.20	0.20	0.20	0.20	0.20	0.20	0.20
Spacing	0.15	0.15	0.15	0.11	0.11	0.11	0.11	0.11	0.11	0.11	0.11	0.11
Smax	18	18	18	18	12	12	18	12	12	18	12	12
S&T min	18	18	18	18	12	12	18	12	12	18	12	12
As req'd	0.28	0.28	0.28	0.20	0.20	0.20	0.20	0.20	0.20	0.20	0.20	0.20
Bars	#4 @ 8	#4 @ 8	#4 @ 8	#4 @ 12	#4 @ 12	#4 @ 12	#4 @ 12	#4 @ 12	#4 @ 12	#4 @ 12	#4 @ 12	#4 @ 12
As Prov'd (In2)	0.30	0.30	0.30	0.20	0.20	0.20	0.20	0.20	0.20	0.20	0.20	0.20
Transverse	#4 @ 12	#4 @ 12	#4 @ 12	#4 @ 12	#4 @ 12	#4 @ 12	#4 @ 12	#4 @ 12	#4 @ 12	#4 @ 12	#4 @ 12	#4 @ 12
As Prov'd (In2)	0.20	0.20	0.20	0.20	0.20	0.20	0.20	0.20	0.20	0.20	0.20	0.20

<< match mech roof for construction ease

		#5		#4																			
		bb		Ab		d																	
		0.3		0.5		0.20		0.20		0.20		0.20		0.20		0.20		0.20		0.20			
		4		4		4		4		4		4		4		4		4		4			
<b>Third Floor</b>																							
		bb	Ab	d																			
		5.8		6		4.35		8.7		8.7		7.2		7.7		7.7		7.2		7.2			
10.1	8.5	8.5	11.6	11.6	11.6	11.6	11.6	11.6	10.1	10.1	10.1	10.6	10.6	11.6	11.6	11.6	11.6	8.7	8.7	8.7	8.7		
8.6	7.5	7.5	10.1	10.1	10.1	10.1	10.6	10.6	10.1	10.1	10.1	10.6	10.6	11.6	11.6	11.6	11.6	7.2	7.2	7.2	7.2		
-1/10	+1/16	-1/11	-1/24	+1/11	-1/10	-1/11	+1/16	-1/11	0.04	0.09	0.10	0.06	0.09	-1/11	-1/10	+1/16	-1/11	0.06	0.09	0.06	0.09		
0.10	0.06	0.09	0.04	0.09	0.10	0.06	0.06	0.09	0.04	0.09	0.10	0.06	0.09	-1/10	-1/10	+1/16	-1/11	0.06	0.09	0.06	0.09		
2144.8	1019.5	1483.0	592.1	3060.3	3366.3	2317.4	3370.8	3370.8	1402.6	3060.3	3366.3	2317.4	3370.8	3370.8	1107.5	1218.2	870.8	564.6	821.2	763.5	318.1	694.1	
0.106	0.050	0.073	0.029	0.064	0.151	0.166	0.114	0.166	0.069	0.151	0.166	0.114	0.166	0.166	0.031	0.075	0.054	0.035	0.051	0.047	0.020	0.043	
0.156	0.074	0.108	0.043	0.094	0.222	0.244	0.188	0.245	0.102	0.222	0.244	0.188	0.245	0.245	0.046	0.111	0.079	0.115	0.075	0.069	0.029	0.063	
0.097	0.046	0.067	0.026	0.058	0.139	0.153	0.105	0.154	0.063	0.139	0.153	0.105	0.154	0.154	0.028	0.069	0.049	0.071	0.046	0.043	0.018	0.039	
--	--	--	--	--	1916	--	--	--	--	--	--	--	--	--	973	--	--	--	--	--	--	770	--
1247	1088	1088	--	1667	1667	1749	1749	1749	--	1667	1667	1749	1749	1749	--	846	846	905	729	729	729	670	670
5692	5692	5692	5692	5692	5692	5692	5692	5692	5692	5692	5692	5692	5692	5692	4554	4554	4554	4554	4554	4554	4554	4554	4554
OK	OK	OK	OK	OK	OK	OK	OK	OK	OK	OK	OK	OK	OK	OK	OK	OK	OK	OK	OK	OK	OK	OK	OK
0.19	0.19	0.19	0.19	0.19	0.19	0.19	0.19	0.19	0.19	0.19	0.19	0.19	0.19	0.19	0.15	0.15	0.15	0.15	0.15	0.15	0.15	0.15	
0.20	0.20	0.20	0.20	0.20	0.20	0.20	0.20	0.20	0.20	0.20	0.20	0.20	0.20	0.20	0.16	0.16	0.16	0.16	0.16	0.16	0.16	0.16	
0.11	0.11	0.11	0.11	0.11	0.11	0.11	0.11	0.11	0.11	0.11	0.11	0.11	0.11	0.11	0.09	0.09	0.09	0.09	0.09	0.09	0.09	0.09	
					18				18						15							18	
					12				12						12							12	
					18				18						18							18	
					0.20				0.20					0.20								0.16	
					0.20				0.20					0.20								0.16	
					#4 @ 12				#4 @ 12					#4 @ 12								0.16	
					0.20				0.20					0.20								0.16	
					#4 @ 12				#4 @ 12					#4 @ 12								0.16	
					0.20				0.20					0.20								0.16	



GRAVITY - BEAMS

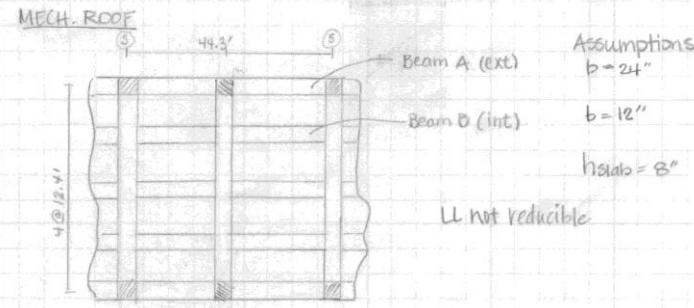

GRAVITY - BMS

Beam A: ext. b.m  $b = 24"$

Beam B: Intc. b.m

$h = \frac{l}{21} = \frac{49.3}{21} = 2.35 \approx 14"$  try deeper for deflections.

$l = 21.2$

LL =  $125 \times 12.4 / 2 = 775$  PLF  
 DL = slab + 2RIF wt + Superimp.  
 $= \frac{8}{12} \times 150 \times 12.4 / 2 + \frac{24}{12} \times \frac{150}{12} \times 150$   
 $+ 20 \times 12.4 / 2$   
 $= 1194$  PLF  $W_u = 2.69$  klf

$= 1550$  PLF  
 $= \frac{8}{12} \times 150 \times 12.4 + 2 \times \frac{150}{12} \times 150 + 20 \times 12.4$   
 $= 1938$  PLF  $W_u = 1.22 + 1.66 = 4.84$  klf

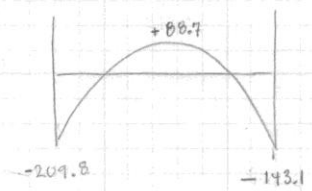
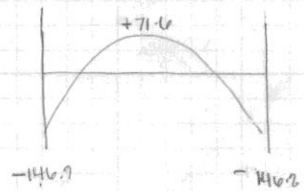

VALUES CONFIRMED VIA STAAD

Midspar

Midspar

$d = h - c_c - d_b / 2$   
 $= 26 - 1.5 - 0.215 / 2$   
 $= 24.19$

$d = h - c_c - d_b / 2$   
 $= 24.19$

$A_s = \frac{M_u}{\phi d} = \frac{71.6}{4(24.19)} = 0.74 \text{ in}^2$

$A_s = \frac{88.7}{4(24.19)} = 0.92$

try (7) #5s  $A_s = 2.17$

try (7) #5s  $A_s = 2.17$

$a = \frac{2.17(60)}{0.85(41(94))} = 1.60$

$a = 1.60$

$c = a / \beta = 1.88$   
 $\epsilon_s = \epsilon_u (d - c) / c = 0.04$  ✓ ok

$c = 1.88$   
 $\epsilon_s = 0.04$  ✓ ok  $\phi = 0.9$

$\phi M_n = A_s f_y (d - a / 2)$   
 $= 2.17(60)(24.19 - 1.60 / 2)$   
 $= 228.4$  kft

$\phi M_n = 0.9(2.17)(60)(24.19 - 1.60 / 2)$   
 $= 228.4$  kft

$\phi M_n = 228.4 > M_u = 71.6$  kft ✓ ok

$\phi M_n = 228.4 > M_u = 88.7$

$A_{smin} = \max \left\{ \begin{array}{l} 3(\rho_c b_w d) / f_y = 1.89 \\ 200 b_w d / f_y = 1.93 \end{array} \right.$

$A_{smin} = \left\{ \begin{array}{l} 1.89 \\ 1.93 \end{array} \right.$  ✓ ok

$\therefore (7) \#5$  ok.

<p>@ Supports: left = Right  <math>M_u = 146.9</math>  <math>A_s = \frac{M_u}{4d} = \frac{146.9}{4(24.19)} = 1.53</math>                  try (4) #7s  <math>A_s = 2.40</math>  <math>a = \frac{A_s f_y}{.85 f'_c b} = 1.76</math>  <math>\rightarrow c = 2.08</math>  <math>\epsilon_s = 0.03</math>  <math>\therefore \phi = 0.9</math>  <math>\phi M_n = \phi A_s f_y (d - a/2) = 250.3</math>  <math>\phi M_n = 250.3 &gt; M_u = 146.9 \text{ kft}</math>                  ✓ok</p>	<p>@ Supports: left  <math>M_u = 209.8</math>  <math>A_s = \frac{209.8}{4(24.19)} = 2.19 \text{ in}^2</math>                  try (4) #8s <math>A_s = 2.27 \text{ in}^2</math>  <math>a = \frac{2.37(60)}{.85(47)(24)} = 1.61</math>  <math>\therefore c = 1.89 \rightarrow \epsilon_s = .04 \neq 0.9</math>  <math>\phi M_n = 0.9(2.37)(60)(24.0 - 1.61/2) = 247.4</math>  <math>\phi M_n = 247.4 &gt; M_u = 209.8 \text{ kft}</math>                  ✓ok</p>
<p><u>Vertical Shear</u>  <math>V_u = \frac{w_u l_n}{2} = \frac{2.69(21.2)}{2} = 28.51</math>  <math>\phi V_n = 0.75(2\sqrt{4000}) \left( \frac{24.06}{2} + 2(60^k)(24.06)(12) \right)</math>  <math>= 74.6 \text{ k}</math>  <math>\phi V_n = 74.6 \text{ k} &gt; V_u = 28.5</math>                  ✓ok                  using 2#9s @ 12" o.c.</p>	<p>@ Sup.: Right  <math>M_u = 143.1</math>  <math>A_s \text{ req'd} = \frac{143.1}{2(24.19)} = 1.49</math>                  try (2) #8s <math>A_s = 1.58 \text{ in}^2</math>  <math>a = 1.16 \rightarrow c = 1.37</math>  <math>\epsilon_s = 0.05 \quad \phi = 0.9</math>  <math>\phi M_n = 0.9(1.58)(60)(24 - 1.16/2) = 166.5</math>  <math>\phi M_n = 166.2 &gt; M_u = 143.1 \text{ ft-k}</math>                  ✓ok</p>
<p><u>Vertical Shear</u>  <math>V_u = \frac{4.84 \times 21.2}{2} = 51.30</math>  <math>\phi V_n = 0.75(2\sqrt{4000}) \left( \frac{24.06}{2} + .4(60^k)(24)(12) \right)</math>  <math>= 90.64 \text{ k} &gt; 51.3 \text{ k}</math>                  ✓ok                  using 2#3s @ 12" o.c.</p>	<p><u>Vertical Shear</u>  <math>V_u = \frac{4.84 \times 21.2}{2} = 51.30</math>  <math>\phi V_n = 0.75(2\sqrt{4000}) \left( \frac{24.06}{2} + .4(60^k)(24)(12) \right)</math>  <math>= 90.64 \text{ k} &gt; 51.3 \text{ k}</math>                  ✓ok                  using 2#3s @ 12" o.c.</p>

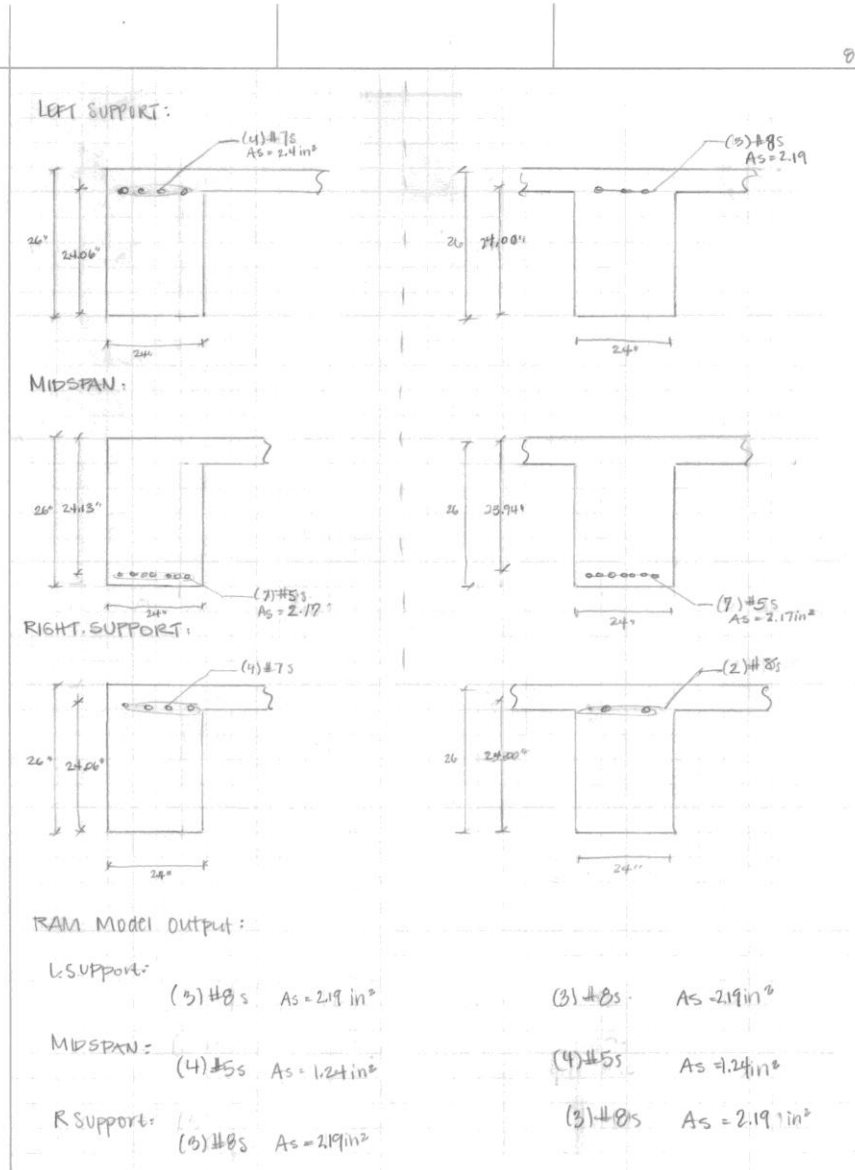

Excel Spreadsheet:

Input	Units	Mechanical Roof		Roof		Fourth Floor		Third Floor		Second Floor	
		Beam A (exterior)	Beam B (interior)	Beam A (exterior)	Beam B (interior)	Beam A (exterior)	Beam B (interior)	Beam A (exterior)	Beam B (interior)	Beam A (exterior)	Beam B (interior)
slab		8	8	6	6	6	6	6	6	5	5
b		26.0	26.0	24.0	24.0	24.0	24.0	20.0	20.0	20.0	20.0
h		12.11	12.11	18.29	18.29	13.31	13.31	10.11	10.11	10.11	10.11
Used beam depth	in	14.0	14.0	20.0	20.0	24.0	24.0	24.0	24.0	24.0	24.0
l	ft	22.2	22.2	33	33	24.3	24.3	18.7	18.7	18.7	18.7
l <sub>1</sub>	ft	21.2	21.2	32	32	21.2	21.2	17.7	17.7	17.7	17.7
l <sub>2</sub>	ft	6.2	6.2	11.64	11.64	6.375	6.375	5.8	5.8	5.8	5.8
trib width	ft	26.90	26.90	48.40	48.40	26.90	26.90	18.99	18.99	18.99	18.99
Wu	pif	146.9	209.8	51.55	51.55	132.55	168.99	5.02	5.02	5.02	5.02
Mu+ (Left)	k-ft	74.13	88.70	17.94	17.94	31.63	31.63	137.87	36.61	36.61	36.61
Mu+ (Right)	k-ft	36.37	44.20	7.60	7.60	13.86	13.86	5.77	5.77	5.77	5.77
Mu- (Left)	k-ft	71.60	88.70	17.94	17.94	31.63	31.63	137.87	36.61	36.61	36.61
Mu- (Right)	k-ft	36.37	44.20	7.60	7.60	13.86	13.86	5.77	5.77	5.77	5.77
Midspan (Bottom)		146.20	146.20	70.92	52.48	180.94	217.20	124.64	6.95	132.91	132.91
Trial Bar Size		#5	#5	#5	#5	#7	#7	#6	#6	#9	#10
db		0.625	0.625	0.625	0.625	0.875	0.875	0.625	0.625	1.128	1.270
Ab		0.310	0.310	0.310	0.310	0.600	0.600	0.440	0.440	1.000	1.270
d		28.19	28.19	18.19	18.19	24.06	24.06	22.06	22.06	23.94	31.87
As req'd		0.74	0.74	0.74	0.74	1.37	1.37	1.56	1.56	2.10	4.96
Min # of bars		3	3	3	3	3	3	3	3	2	3
Max # of bars		11	11	4	4	11	11	11	11	4	9
AS prov'd		2.17	1.86	0.83	0.83	2.40	2.40	1.80	1.76	4.00	7.62
a		1.60	1.37	0.68	0.68	1.76	1.76	1.55	1.55	2.94	4.88
b		1.88	1.71	0.80	0.80	1.97	1.97	1.83	1.83	3.46	5.27
cs		0.04	0.05	0.06	0.06	0.03	0.03	0.03	0.03	0.02	0.02
GMh		228.40	268.06	96.29	74.68	368.37	472.27	40.92	169.08	404.38	1015.80
CHECK		OK	OK	OK	OK	OK	OK	OK	OK	OK	OK
Asmin		1.84	2.32	0.92	1.38	1.83	1.40	0.64	1.40	1.82	3.02
Asmin		1.94	2.44	0.98	1.46	1.93	1.47	0.68	1.48	1.91	3.19
Supports (Top) LEFT											
Trial Bar Size		#7	#8	#7	#6	#8	#7	#7	#7	#7	#7
db		0.875	1.000	0.875	0.750	0.875	0.875	0.875	0.875	0.875	0.875
Ab		0.600	0.790	0.600	0.440	0.600	0.600	0.600	0.600	0.600	0.600
d		24.06	28.00	12.06	18.13	24.13	24.13	22.06	22.06	24.06	32.06
As req'd		1.53	1.87	1.47	0.72	1.88	2.25	1.41	1.41	1.50	1.38
Min # of bars		3	2	3	2	3	2	3	3	2	3
Max # of bars		11	4	11	4	11	4	11	11	4	11
AS prov'd		2.40	2.37	1.80	1.76	2.20	2.20	1.80	1.80	2.40	3.00
a		1.76	1.27	1.32	0.53	1.62	1.62	1.59	1.59	1.02	1.76
b		2.08	1.50	1.56	0.63	1.90	1.87	1.87	1.87	1.19	2.08
cs		0.03	0.05	0.02	0.08	0.04	0.04	0.03	0.03	0.06	0.04
GMh		250.3	291.8	92.3	141.4	230.8	172.3	42.3	231.1	254.4	420.9
CHECK		OK	OK	OK	OK	OK	OK	OK	OK	OK	OK
Asmin		1.83	2.30	0.92	1.38	1.83	1.40	0.64	1.40	1.83	3.04
Asmin		1.93	2.43	0.97	1.45	1.93	1.47	0.68	1.47	1.93	3.21
Supports (Top) RIGHT											
Trial Bar Size		#7	#8	#7	#6	#7	#7	#7	#7	#7	#7
db		0.875	1.000	0.875	0.750	0.875	0.875	0.875	0.875	0.875	0.875
Ab		0.600	0.790	0.600	0.440	0.600	0.600	0.600	0.600	0.600	0.600
d		24.06	28.00	12.06	18.13	24.13	24.13	22.06	22.06	24.06	32.06
As req'd		1.52	1.88	1.47	0.72	1.88	2.25	1.41	1.41	1.50	1.38
Min # of bars		3	2	3	2	3	2	3	3	2	3
Max # of bars		11	4	11	4	11	4	11	11	4	11
AS prov'd		2.40	2.37	1.80	1.76	2.20	2.20	1.80	1.80	2.40	3.00
a		1.76	1.27	1.32	0.53	1.62	1.62	1.59	1.59	1.02	1.76
b		2.08	1.50	1.56	0.63	1.90	1.87	1.87	1.87	1.19	2.08
cs		0.03	0.05	0.02	0.08	0.04	0.04	0.03	0.03	0.06	0.04
GMh		250.3	291.8	92.3	141.4	230.8	172.3	42.3	231.1	254.4	420.9
CHECK		OK	OK	OK	OK	OK	OK	OK	OK	OK	OK
Asmin		1.83	2.30	0.92	1.38	1.83	1.40	0.64	1.40	1.83	3.04
Asmin		1.93	2.43	0.97	1.45	1.93	1.47	0.68	1.47	1.93	3.21
Vertical Shear											
Vu	(k)	28.51	51.30	28.51	51.30	31.34	43.04	10.36	23.81	16.55	87.36
φVc		74.64	92.16	74.64	68.46	60.06	74.64	27.73	60.06	60.06	126.31
CHECK		OK	OK	OK	OK	OK	OK	OK	OK	OK	OK
Bottom bars @ Midspan (+)		7 #5	7 #5	6 #5	3 #5	4 #7	6 #7	3 #5	4 #6	4 #9	6 #10
Top bars @ LEFT Support (-)		4 #7	3 #8	3 #7	4 #6	5 #6	5 #8	3 #5	3 #7	4 #7	5 #7
Top bars @ RIGHT Support (-)		4 #7	3 #8	3 #7	4 #6	5 #6	5 #8	3 #5	3 #7	4 #7	5 #7
Shear Reinforcing		#3 @ 12"	#3 @ 12"	#3 @ 12"	#3 @ 12"	#3 @ 12"	#3 @ 12"	#3 @ 12"	#3 @ 12"	#3 @ 12"	#4 @ 12"
d req'd		24.0	24.0	24.0	24.0	24.0	24.0	24.0	24.0	24.0	30.0
h		24.19	28.19	12.19	18.19	24.13	24.13	22.06	22.06	24.06	32.06
Shear Reinforcing		2 #3 @ 12"	2 #3 @ 12"	2 #3 @ 12"	2 #3 @ 12"	2 #3 @ 12"	2 #3 @ 12"	2 #3 @ 12"	2 #3 @ 12"	2 #3 @ 12"	2 #3 @ 12"

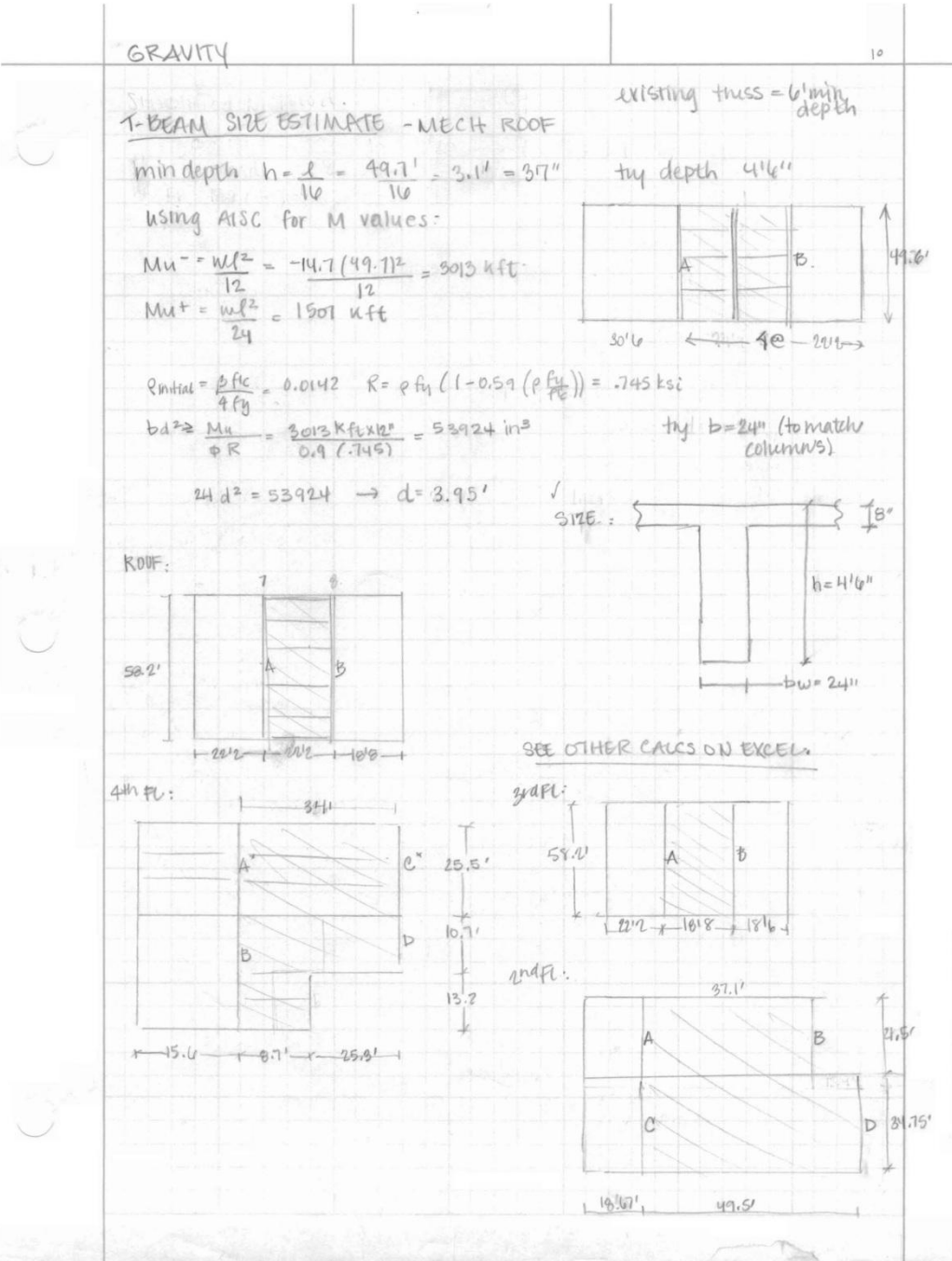

GRAVITY - GIRDER

MECH. RF:

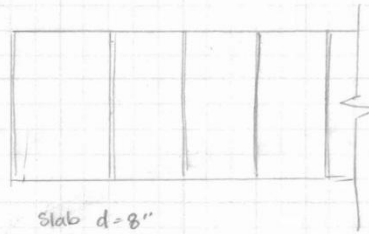
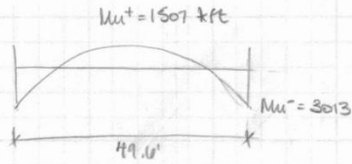

... size estimated (see previous) at  $t = 21''$   $b = 416''$

Wt. self effects:

$$W_s \cdot W = (84'') (4.5 - 9'') \times 150 = 1150 \text{ PLF}$$

$$\omega_u = 14.7 + 1.2(1150)/1000 = 16.1 \quad \therefore \begin{matrix} Mu^- = 3014 \text{ k-ft} \\ Mu^+ = 1657 \end{matrix}$$

req'd steel:

$$A_s = \frac{Mu}{\phi d} = \frac{3014}{4(4.5' \times 12'')} = 15.3 \text{ in}^2 \quad \text{try 2 layers of (14) \#10s each layer}$$

using h as estimate

$$d = \frac{A_s f_y}{\phi_s f_c b} = \frac{17.18(60)}{.85(4)(24)} = 19.07 \rightarrow c = 15.38$$

$$\phi M_n = A_s f_y (d - a/2) = (14)(17.18)(60)(49.97 - 15.38/2) = 41703 \text{ kin} = 3475 \text{ k-ft}$$

$$\phi M_n = 3475 \text{ k-ft} > Mu = 3014 \text{ k-ft}$$

Midspar  $\checkmark$

ck ductility

$$E_s = .003(49.97 - 15.38) / 15.38 = .0067 > .005 \text{ ok}$$

$A_s = 17.78 \text{ in}^2$  using stirrups

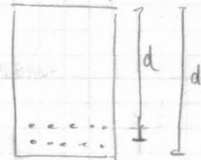

$$d_t = 4.5 \times 12 - 1.5 - 9/8 - 1.2/2 = 51.24''$$

$$d = 4.5 \times 12 - 1.5 - 9/8 - 1.27 \times 1.5 = 49.97''$$

Ends:

$$A_s = 7.65 \text{ in}^2 \quad \text{try 1 layer (7) \#10s} \rightarrow A_{sp} = 8.89 \text{ in}^2$$

$$a = 6.54 \rightarrow c = 7.69 \rightarrow E_s = .0169 > .005 \text{ ok}$$

$$\phi M_n = 0.9(8.89)(60)(51.24 - 6.54/2) = 23029 \text{ kin} = 1919 \text{ k-ft} > Mu = 1657 \checkmark \text{ ok}$$

2

check min:

$$A_{smin} = 200 (24) (49.97) / 60 = 40 \text{ in}^2 \text{ ok for both}$$

$$V_u = \frac{W_u L_n}{2} = \frac{16.1 \text{ k/ft} (49.97' - d)}{2} = 399.8 \text{ k}$$

$$\phi V_n = 0.75 \left( 2 \sqrt{4000} \times \frac{24 (49.97)}{1000} + V_s \right) \geq 399.8 \text{ k}$$

$$113.8 \text{ k} + V_s \geq 399.8 \text{ k} \rightarrow V_s > 270 \text{ k} < \text{Biffel bwd } \checkmark \text{ ok}$$

$$V_s = A_v f_y t \frac{d}{s}$$

$$s = A_v f_y t \frac{d}{V_s} = \frac{0.31 (60) (49.97)}{270} = 3.4" \rightarrow \text{use } \#5s \text{ use } 3" \text{ spacing}$$

start w #5s @ 3" spacing tip.

check:

$$113.8 + 309.8 = 423.4 > 399.8 \text{ k } \checkmark \text{ ok}$$

Design:

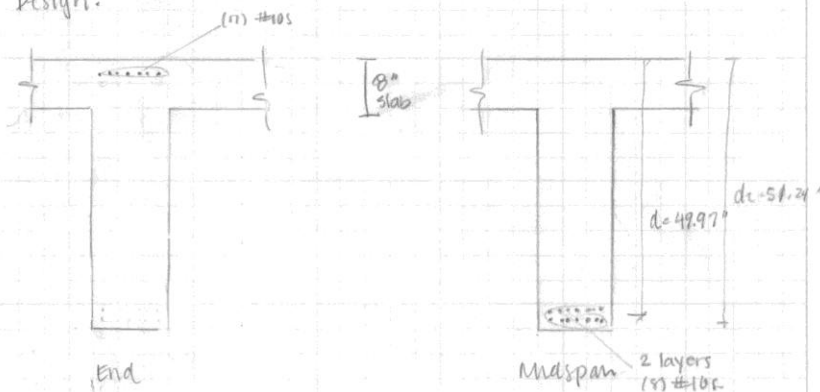

comparable to RAM design output

Interior Beam E-5 to E-6

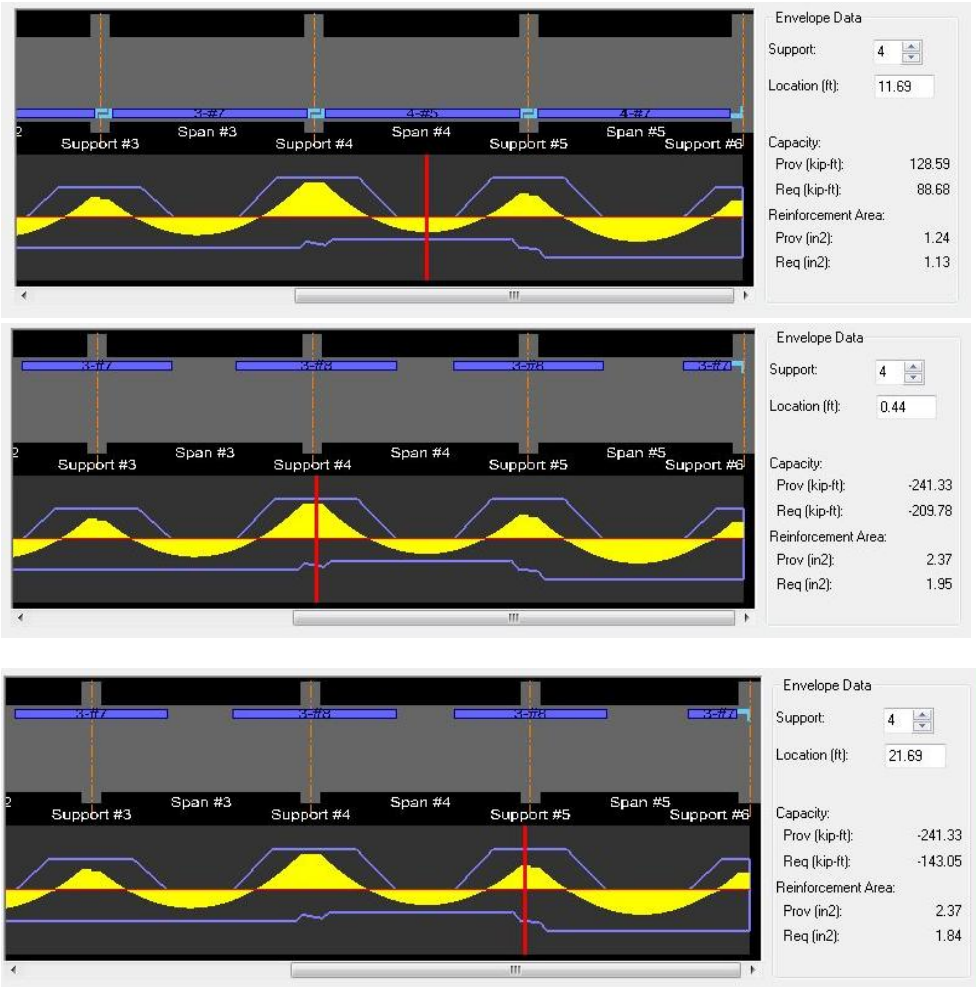



Prestressed System:

**GRAVITY-PT. DESIGN**  
**MECH ROOF SYSTEM.**

AS PREVIOUSLY; FOR GIRDER

$M_u^- = 303 \text{ kft}$   
 $M_u^+ = 1507 \text{ kft}$

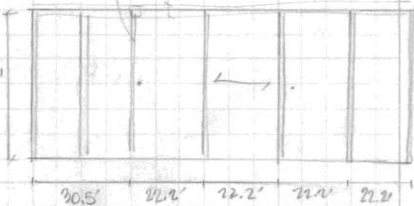

FOR SLAB:

$M_u^- = \frac{w l^2}{11} = \frac{-211 (22.2 - 24/12)^2}{11} = -12.2 \text{ kft}$   
 $M_u^+ = \frac{w l^2}{16} = \frac{+211 (22.2 - 24/12)^2}{16} = 8.4 \text{ kft}$

compr stresses:  $\sigma_{ci} = 0.6 \text{ fci}$  initial  
 $\sigma_{cas} = 0.45 \text{ fci}$  sus  
 $\sigma_{pte} = 0.16 \text{ fci}$

tension:  $\sigma_{Et} = 3 \text{ kft}$   
 $\sigma_{Tus} = 6 \text{ kft}$   
 $\sigma_{Tt} = 6 \text{ kft}$

see APT-PTV & Output

Load	Deflection (")
DL	+0.01
SDU	+0.04
LL	+0.26
PT	-0.19
SUS LL	+0.09

deflection check:  
 by inspection, passes

total load  $\frac{l}{240} = \frac{22.2 \times 19}{240} = 1.11'' \leq .01 + .04 + .26 - .19 = .32''$

live load  $\frac{l}{360} = \frac{22.2 \times 12}{360} = 0.74'' \leq 0.26''$

sust. load  $\frac{l}{480} = 0.56'' \leq .01 + .04 + .09 - .19 = .15''$

GOOD FOR SERVICEABILITY & STRENGTH ✓

**GIRDER:**

$M_u^- = 303 \text{ kft}$   
 $M_u^+ = 1507 \text{ kft}$   
 $l = 49.6$   
 SPAN,  $b = 24''$   
 TRIB W = 22.2' total by  $\leq 8.12 \leq \frac{1}{4}(l) = 12.4' = 148.8''$

$h = 35' \times 12 = 42''$

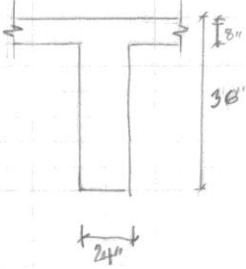

$f_c = 5000 \therefore E = 40300^3$   
 $f_{ci} = 4000$

deflection passes by inspection

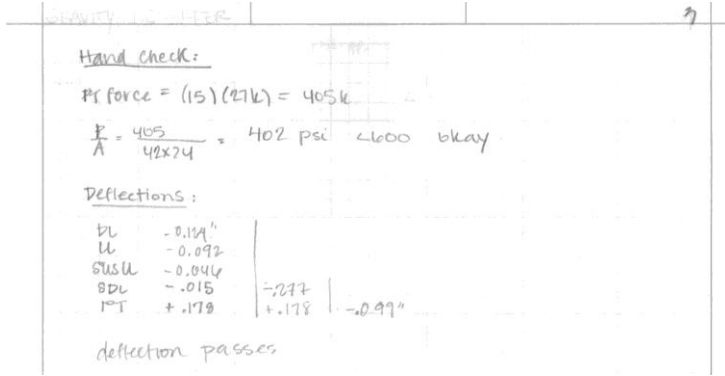

Slab

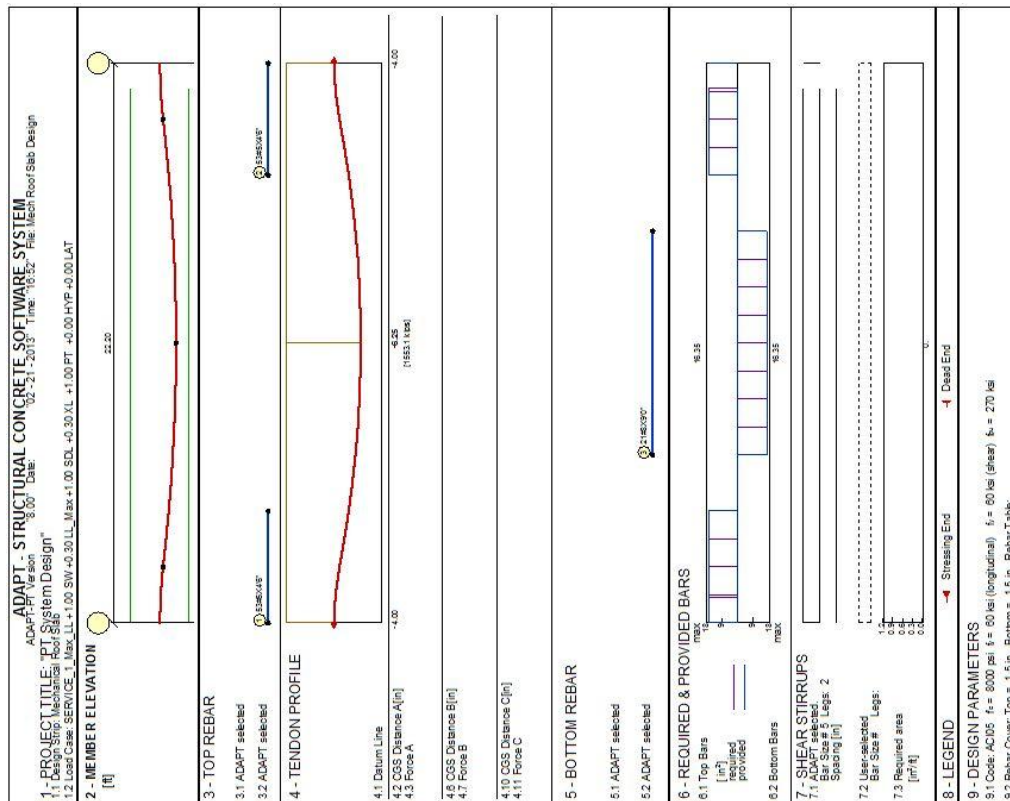
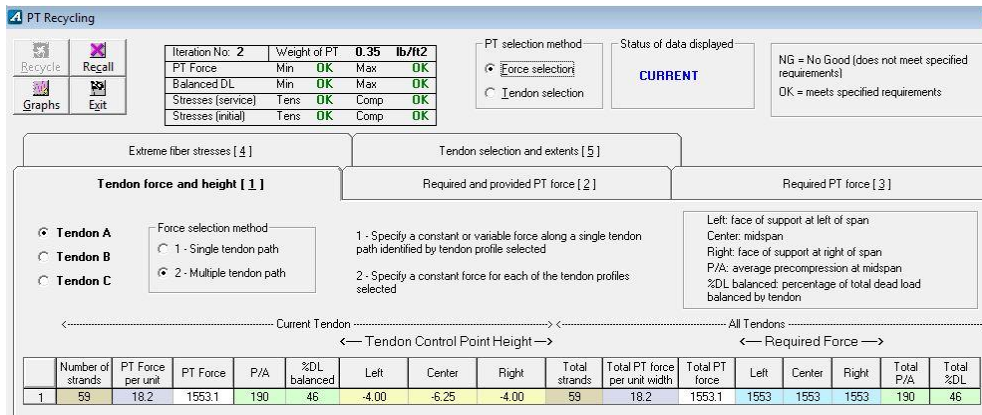

**PT Recycling**

Recycle	Recall	Iteration No: 2	Weight of PT	0.63	lb/ft <sup>2</sup>	
Graphs	Exit	PT Force	Min	OK	Max	OK
		Balanced DL	Min	OK	Max	OK
		Stresses (service)	Tens	OK	Comp	OK
		Stresses (initial)	Tens	OK	Comp	OK

PT selection method:  Force selection  Tendon selection

Status of data displayed: **CURRENT**

NG = No Good (does not meet specified requirements)  
OK = meets specified requirements

Extreme fiber stresses [4]      Tendon selection and extents [5]

**Tendon force and height [1]**

Force selection method:  
 1 - Single tendon path  
 2 - Multiple tendon path

1 - Specify a constant or variable force along a single tendon path identified by tendon profile selected  
 2 - Specify a constant force for each of the tendon profiles selected

Left: face of support at left of span  
 Center: midspan  
 Right: face of support at right of span  
 P/A: average precompression at midspan  
 %DL balanced: percentage of total dead load balanced by tendon

Current Tendon      ← Tendon Control Point Height →      All Tendons

	Number of strands	PT Force per unit	PT Force	P/A	%DL balanced	Left	Center	Right	Total strands	Total PT force per unit width	Total PT force	Left	Center	Right	Total P/A	Total %DL
1	15	32.4	401.3	200	129	-12.54	-40.25	-12.54	15	32.4	401.3	401	401	401	200	129

Beams:

**ADAPT - STRUCTURAL CONCRETE SOFTWARE SYSTEM**  
 ADAPT Version: 8.001      Date: 02-21-2013 11:48:52 AM      File: Mech Roof Slab Design

1 - PROJECT TITLE: "PT System Design"  
 1.1 Design Strip: Mechanical Roof Slab  
 1.2 Load Case: SERVICE\_1\_Max\_LL+1.00 SW+0.30 LL\_Max+1.00 SDL+0.30 XL+1.00 PT +0.00 HYF+0.00 LAT

2 - MEMBER ELEVATION [ft]

3 - TOP REBAR

3.1 ADAPT selected  
 3.2 ADAPT selected

4 - TENDON PROFILE

4.1 Datum Line  
 4.2 CGS Distance A [in]      -4.00  
 4.3 Force A      (1553.1 lbs)  
 4.6 CGS Distance B [in]      -4.25  
 4.7 Force B  
 4.10 CGS Distance C [in]      -18.35  
 4.11 Force C

5 - BOTTOM REBAR

5.1 ADAPT selected  
 5.2 ADAPT selected

6 - REQUIRED & PROVIDED BARS

6.1 Top Bars [in] required provided  
 6.2 Bottom Bars [in] required provided

7 - SHEAR STIRRUPS

7.1 ADAPT selected  
 Bar Size #      5      Legs: 2      Spacing [in]      u  
 7.2 User-selected Bar Size #      5      Legs:      2  
 7.3 Required area [in<sup>2</sup>/ft]

8 - LEGEND  
 ← Stressing End      → Dead End

9 - DESIGN PARAMETERS  
 9.1 Code: ACI 308      f'c = 8000 psi      f = 60 ksi (longitudinal)      f = 60 ksi (shear)      f<sub>w</sub> = 270 ksi  
 9.2 Rebar Cover: Top = 1.5 in      Bottom = 1.5 in      Rebar Table:

## Comparison

Reinforced Concrete One Way Slab & Beam					
System Components	Quantity	Unit	Cost per SF (\$)		
			Material	Installation	Total
Forms in place, flat plate to 15' high, 4 uses	1655.68	S.F.	1.56	6.30	7.86
Forms in place, interior beam, 24", 4 uses	877.9	SFCA	0.26	2.55	2.59
Reinforcing in place, elevated slabs #4 to #7	3.1	Ton	1.49	0.77	2.26
Reinforcing in place, elevated beams #10	1.0	Ton	0.45	0.27	0.72
Reinforcing in place, elevated beams #4 to #7	0.5	Ton	0.22	0.22	0.45
Concrete ready mix, regular weight, 4000 psi	70.02	CY	3.30	0.00	3.30
Place and vibrate concrete, elevated slab 6" to 10" thick, pump	70.02	CY	0.00	0.64	0.64
Cure with sprayed membrane curing compound	25.34	C.S.F.	0.09	0.07	0.15
<b>Total SF</b>	<b>2186.80</b>			<b>Total (\$/sf)</b>	<b>17.96</b>

Prestressed One-Way Slab & Beam					
System Components	Quantity	Unit	Cost per SF (\$)		
			Material	Installation	Total
Forms in place, flat plate to 15' high, 4 uses	2007.9	S.F.	1.89	7.64	8.75
Forms in place, interior beam, 24", 4 uses	240.2	SFCA	0.07	0.70	0.71
Reinforcing in place, elevated slabs #4 to #7	1.6	Ton	0.78	0.40	1.18
Reinforcing in place, elevated beams #4 to #7	0.7	Ton	0.32	0.32	0.65
Concrete ready mix, regular weight, 5000 psi	65.0	CY	3.24	0.00	3.24
Place and vibrate concrete, elevated slab 6" to 10" thick, pump	65.0	CY	0.00	0.59	0.59
Cure with sprayed membrane curing compound	20.1	C.S.F.	0.07	0.05	0.12
Pre-Stressing Tendons	3530.38	Lb.	1.02	2.00	4.41
<b>Total SF</b>	<b>2186.80</b>			<b>Total (\$/sf)</b>	<b>19.64</b>

Existing - Composite Steel					
System Components	Quantity	Unit	Cost per SF (\$)		
			Material	Installation	Total
W24x55	37.2	LF	1.14	0.08	1.23
W24w76	198.0	LF	8.40	0.45	8.85
W16x31	49.5	LF	0.86	0.11	0.97
W30x90	22.4	LF	1.24	0.05	1.29
Welded Shear Connectors 3/4" diameter 3-7/8" long	240.5	Ea.	0.12	0.14	0.26
Metal decking, non cellular composite, galv. 2" deep, 20 gauge	2215.1	S.F.	1.83	0.47	2.30
Sheet metal edge closure form, 12" w/2 bends, 18 ga, galv	188.5	L.F.	0.09	0.09	0.17
Welded wire fabric rolls, 6 x 6 - W1.4xW1.4 (10x10), 21 lb/csf	22.2	C.S.F.	0.14	0.23	0.36
Concrete ready mix, normal weight, 3000 psi	20.5	CY	0.95	0.00	0.95
Place and vibrate concrete, elevated slab less than 6", pumped	20.5	CY	0.00	0.21	0.21
Curing with spread membrane curing compound	22.2	C.S.F.	0.07	0.06	0.13
Sprayed mineral fiber/cement for fireproof, 1" thick on beams	2215.1	S.F.	0.53	0.68	1.21
<b>Total SF</b>	<b>2215.13</b>			<b>Total (\$/sf)</b>	<b>17.93</b>

Columns & Walls:

Hand calculations:

**GRAVITY-COLUMNS**

LOOK AT EXTERIOR COL. F 8.8 & INTERIOR COL E 8.8

20x24 beams  
w d.  
slab = 6"  
LL = 30 PSF

23.2' 12.7'

15.5' 6.8' 10.1' 23.8'

TTlb Area =  $(7.75 + 17) \times (76.5 / 2 + 23.2 / 2)$   
= 615.0

**AT ROOF:**

**EXTERIOR:** 147.9  
 $LL = 1.6 \times (5 + 7.75) \times (23.2 / 2) \times 30 = 71.1k$

**INTERIOR:**  
 $LL = 1.6 \times (30) \times (615.0) = 29.5k$

**PL:**

SLAB =  $\frac{6}{12} \times 145 \times 17.9 = 10.7$       =  $\frac{6}{12} \times 145 \times 61.5 = 44.6$

$B_{med} = 12.75 \times 145 \times \left(\frac{29}{12}\right) \left(\frac{19}{12}\right) = 4.6$       =  $2 \times (7.75 + 17) \times 145 \times \frac{29}{12} \times \frac{19}{12} = 17.9$

$B_m = 12.75 \times 145 \times \frac{29}{12} \times \frac{19}{12} = 4.6$       =

Col sw =  $17.5 \times 145 \times \frac{24}{12} \times \frac{24}{12} = 10.2$       =  $17.5 \times 145 \times \frac{24}{12} \times \frac{24}{12} = 10.2$

$\frac{1.2 \times 30.1 k}{= 36.0 k}$        $\frac{1.2 \times 72.7}{= 87.2 k}$

**RAM OUTPUT:**

L:  $1.6 \times 4.0k = 6.5$        $1.6 \times 21.0 = 33.6k$

D:  $1.2 \times 25.2 = 30.2$        $1.2 \times 79.0 = 88.8k$  } off by 5%

values comparable.

$P_u = 43.1k$        $P_u = 122.4k$

E-W:  $-6.15kft$        $-2.72kft$        $-42.5$        $-125.2kft$        $82.7kft$

N-S:  $-57.8kft$        $-166.8$        $-222.8$        $50kft$

2

TRIAL SIZE = 24 x 24  
EXTERIOR: N-S direction  $L_u = 16.5'$  unsupported

$e = \frac{M_u}{P_u} = \frac{59.8 \times 16}{43.1} = 16''$  → ck slenderness  
 $\frac{L_u}{h} = \frac{16.5 \times 12}{24} = 8.3 \leq 8.4$  ✓ ok

$\frac{e}{h} = \frac{16}{24} = .67$  bars in 2 faces

$\therefore Y = [24 - 2(2.5)] / 24 = .79$  → Fig A-9b  $\frac{\phi P_n}{b h} = 0.9 \Rightarrow b = h = 6.9$  ✓ ok

<p>Fig A-9b  <math>P_g = .003</math> <math>e/h = .65</math></p> <p><math>\frac{\phi P_n}{b h} = \frac{43.1}{24^2} = .07</math></p> <p><math>\frac{\phi M_n}{b h^2} = \frac{59.8 \times 16}{24^3} = .05</math></p> <p><math>P_g = 1\%</math></p>	<p>Fig A-9c  <math>P_g = .003</math> <math>e/h = .65</math></p> <p><math>\frac{\phi P_n}{b h} = 0.07</math></p> <p><math>\frac{\phi M_n}{b h^2} = 0.05</math></p>
-----------------------------------------------------------------------------------------------------------------------------------------------------------------------------------------------------------------------------------------------------	-----------------------------------------------------------------------------------------------------------------------------------------------------------------------

$A_{s, req'd} \approx 10.9$   $P_{req'd} > 1\%$

$A_s = P_g A_c = 0.01 (24)^2 = 5.76 \text{ in}^2$  → use (6) #9s  $A_s = 6.0 \text{ in}^2$  ✓ ok

TIES: #4s @  $S_{max} = \min \begin{cases} 16 \text{ dbc} = 16(1.128) = 16'' \\ 48 \text{ dbc} = 48(0.5) = 24'' \\ 5(24'') = 12'' \end{cases}$  @ 12" o.c.

INTERIOR:

$e = \frac{82.7 \times 12}{122.4} = 8.1''$  slenderness still not okay

$\frac{e}{h} = \frac{8.1}{24} = .34$

$\therefore Y = [24 - 2(2.5)] / 24 = .79$  Fig A-9b  $\frac{\phi P_n}{b h} = 1.6 \Rightarrow b = h = 9.0''$  ✓ ok

<p>Fig A-9b  <math>P_g = .03</math> <math>e/h = .34</math></p> <p><math>\frac{\phi P_n}{b h} = \frac{122.4}{24^2} = .21</math></p> <p><math>\frac{\phi M_n}{b h^2} = .07</math></p> <p><math>P_g = 1\%</math></p>	<p>Fig A-9c  <math>P_g = 0.03</math> <math>e/h = .34</math></p> <p><math>\frac{\phi P_n}{b h} = .21</math></p> <p><math>\frac{\phi M_n}{b h^2} = .07</math></p>
-----------------------------------------------------------------------------------------------------------------------------------------------------------------------------------------------------------------------	---------------------------------------------------------------------------------------------------------------------------------------------------------------------

→ use  $A_s = 6 \text{ in}^2$  ✓ ok  
 $> A_{s, req'd}$

TIES: same requirements as above  
 use #4s @ 12" o.c.

3

Design these 2 columns at bottom floor: Full col ht = 64'

		Roof	4th	3rd	2nd	
Ext	DL	21.9				+ Col SW
	LL	30		100	100	(PSF)
Int	DL	75.2k				+ Col SW
	LL	30		100	100	

4th:

EXT:  $U = 125 \text{ PSF} \times (7.75 \times 23.2/2) \times 1.6 + 80 \times 5. \times 23.2/2 \times 1.6 = 18.0$

INT:  $U = (80 \times (7.75/2 + 26.9/2) \times 17 \times 1.6 + 80 \times (4.4 \times 7.75) + 125 (8.9 \times 7.75)) \times 1.6 = 72.0 \text{ K}$

∴ Load on Col:

EXT.  $DL = 21.9 \times 4 + 64 \times 145 \times 4 = 146.5 \text{ K}$   
 + superimp.  
 $LL = (230) \times 1.6 (147.9) + 18 = 72.4$   
 $FR = 217.9 \text{ K}$

INT.  $DL = 75.2 \times 4 + 38.4 = 400 \text{ K}$   
 + super.  
 $LL = (230) \times 1.6 (615) + 72 = 298.3$   
 $FR = 698.3 \text{ K}$

off of RAM Model < 10%

REASON FOR NOT SAME AS RAM -  
 - AREAS OVER GENERALIZED (LARGER) IN HAND CALCS.  
 - DL REDUNDANT IN RAM MODEL  
 { LL MORE CONS. BY HAND, DL BY RAM CALCULATIONS }

EW -7.95  $\left\{ \begin{array}{l} \downarrow P_n \\ -1.78 \\ \downarrow P_n \\ = 5.7 \text{ Kft} \\ \text{unbalanced M} \end{array} \right.$  -9.96  $\left\{ \begin{array}{l} \downarrow P_n \\ -68.71 \\ \downarrow P_n \\ = 58.1 \text{ Kft} \end{array} \right.$

N-S  $\left\{ \begin{array}{l} \downarrow P_n \\ -131.6 \\ \downarrow P_n \\ = 151.6 \text{ Kft} \end{array} \right.$  -325.9  $\left\{ \begin{array}{l} \downarrow P_n \\ -494.8 \\ \downarrow P_n \\ = 168.9 \text{ Kft} \end{array} \right.$

4

DESIGN:

EXTERIOR:

$$e = \frac{M_u}{P_u} = \frac{131.6 \times 12}{217.9} = 7.2''$$

$$\frac{e}{h} = \frac{7.2}{24} = .3$$

$$\therefore \gamma = .79 \quad \text{Fig A-9b} = \frac{\phi P_n}{b h} = 1.8 \rightarrow b = h = 11''$$

Fig A-9b

$$p_g = 0.03 \quad e/h = .3$$

$$\frac{\phi P_n}{b h} = \frac{217.9}{24^2} = .36$$

$$\frac{\phi M_n}{b h^2} = \frac{131.6 \times 12}{24^3} = .11$$

$$\therefore p = 1\%$$

Fig A-9c

$$\frac{\phi P_n}{b h} = .38$$

$$\frac{\phi M_n}{b h^2} = .11$$

$$p = 1\%$$

$$\therefore \text{use } A_s = \rho_g A_c = 5.76 \text{ in}^2 \rightarrow \text{use (6) \#4s } A_s = 6 \text{ in}^2$$

TIES SAME AS ABOVE.

INTERIOR:

$$e = \frac{M_u}{P_u} = \frac{168.9 \times 12}{698.3} = 2.9''$$

$$e/h = 2.9/24 = .1$$

$$\therefore \gamma = .79 \quad \text{Fig A-9b} \quad \frac{\phi M_n}{b h} = 3.2 \Rightarrow b = h = 14.8''$$

Fig A-9b

$$\frac{\phi P_n}{b h} = \frac{698.3}{24^2} = 1.21$$

$$\frac{\phi M_n}{b h^2} = \frac{168.9 \times 12}{24^3} = .15$$

$$p = 1\%$$

$$\therefore \text{use } A_s = \rho_g A_c = 5.76 \text{ in}^2 \text{ req'd } \rightarrow \text{use (6) \#4s}$$

Fig A-9c

$$\frac{\phi P_n}{b h} = 1.21$$

$$\frac{\phi M_n}{b h^2} = .15$$

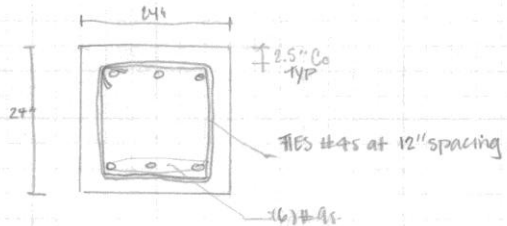



GRAVITY - WALLS  
(BEARING WALLS)

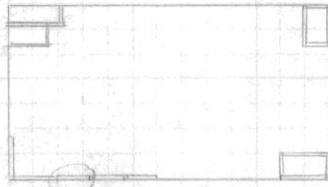

LOAD ON WALL:

SLAB MR =  $150 \times \frac{9}{12} \times 22.2' \times 12.5 \frac{1}{2} = 13.9 \text{ k}$

S.W. a =  $15 \frac{1}{2} \times 22.2' \times \frac{9}{12} \times 150 = 16.7 \text{ k}$

S.W. b =  $(15 \frac{1}{2} + 17 \frac{1}{2}) \times 22.2 \times \frac{9}{12} \times 150 = 35.5 \text{ k}$

S.W. c =  $(15 \frac{1}{2} + 17 \frac{1}{2}) \times 22.2 \times \frac{9}{12} \times 150 = 35.5 \text{ k}$

Slab 2nd =  $150 \times \frac{6}{12} \times 22.2 \times \frac{8.3}{2} = 6.9 \text{ k}$

Slab 1st =  $150 \times \frac{5}{12} \times 22.2 \times \frac{16.6}{2} = 11.6 \text{ k}$

$P_1 = 13.9 + 16.7 = 30.6 \text{ k}$

$P_2 = P_1 + 6.9 + 35.5 = 73 \text{ k}$

$P_3 = P_2 + 11.6 + 35.5 = 120 \text{ k}$

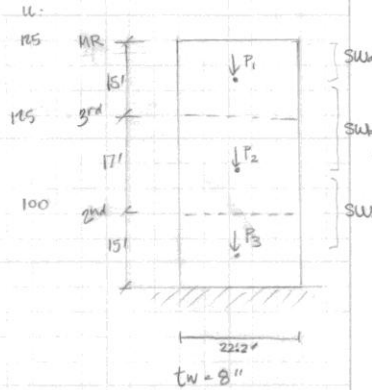

UNELoad:

$P_1 = 125 \text{ PSE} \times 22.2 \times 12.5 \frac{1}{2} = 17.3 \text{ k}$

$P_2 = 125 \times 22.2 \times 8.3 \frac{1}{2} = 11.5 \text{ k}$

$P_3 = 100 \times 22.2 \times 16.6 \frac{1}{2} = 23.0 \text{ k}$

§ 14.5.3.1

$t_{min} = \max \begin{cases} 4" \\ \min \begin{cases} \frac{h}{25} = \frac{17 \frac{1}{2}}{25} = 8.16 \rightarrow \text{use a } 10" \text{ t wall} \\ \frac{l}{25} = \frac{22.2}{25} = \end{cases} \end{cases}$

$\phi P_n > P_u$

$\phi P_n = 0.55 \phi f_c A_g \left[ 1 - \left( \frac{k l_c}{32 h} \right)^2 \right]$

$k = 0.8$

$\phi = 0.65$  § 9.3.2

$f_c = 4000$

$h = 10"$

$l_c = 17' \times 12"$

$A_g = 10" \times 12"$  (per ft length)

2.

$$\phi P_n = 0.55 (0.65) 4000 (10 \times 12) \left[ 1 - \left( \frac{0.8 (17 \times 12)}{32 \times 10} \right)^2 \right]$$

$$= 171,600 (0.594) = 101,860 = 101.9 \text{ k/ft}$$

$$P_u = \left[ 1.2 (90.6 + 73 + 120) + 1.6 (17.3 + 11.5 + 29) \right] / 22.2$$

$$= \frac{391.2}{22.2} = 15.8 \text{ k/ft}$$

$\phi P_n > P_u \quad \checkmark$  therefore ok

§14.3.2.3 Min Reinf:

vert reinf:

(a)  $A_s \geq 0.001 A_g$  where  $\geq \#5$ ,  $f_y = 60 \text{ ksi}$

$$A_s \geq 0.001 (10 \times 12) \text{ ft length}$$

$$= .144 \text{ in}^2/\text{ft} \quad \boxed{\text{use } \#4\text{s @ } 16'' \text{ o.c.}}$$

spacing, max =  $\min \left\{ \begin{array}{l} 18'' \\ 3t = 3(10) = 30'' \end{array} \right.$

$$A_{s \text{ prov'd}} = .20 \text{ in}^2 \left( \frac{16}{16} \right) = .15 \text{ in}^2/\text{ft} > .144 \text{ in}^2/\text{ft} \quad \checkmark \text{ok}$$

horiz reinf

same max spacing

$$A_s \geq .0025 A_g \quad \text{where } \geq \#5\text{s}, f_y = 60 \text{ ksi}$$

$$= .0025 (10 \times 12) = .30 \text{ in}^2/\text{ft} \quad \boxed{\text{use } \#5\text{s @ } 12'' \text{ o.c.}}$$

$$A_{s \text{ prov'd}} = .31 \text{ in}^2/\text{ft} > .30 \text{ in}^2/\text{ft} \quad \checkmark \text{ok}$$

§14.3.6

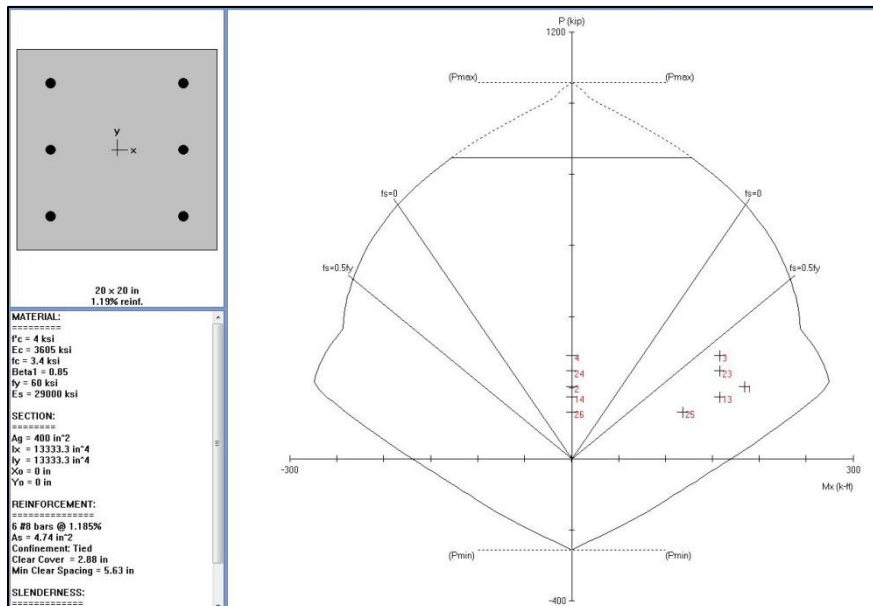
$$A_w = \frac{.15 \text{ in}^2/\text{ft}}{10 \times 12 \text{ in}^2/\text{ft}} = .00125 < .01 A_g \quad \therefore \text{no ties req'd}$$

## Foundations

## FOUNDATIONS

SOIL BEARING CAPACITY: 3000 PSF =  $q_a$ ty  $f_c = 4000$  psi

COLUMN FOUNDATION:

of COL F8.8 - (F9) Square footing

LOAD:  $P_u = 1.2(150.44) + 1.6(43.50) = 250.22$  k

L = B:

$$\text{sizing: } \frac{P}{A} \leq q_a \quad \frac{150.44 + 43.54}{B^2} \leq 3000$$

$$B \geq 8.0'$$

design:

$$q = \frac{250.22 \text{ k}}{8 \times 8 \text{ ft}^2} = 3.9 \frac{\text{k}}{\text{ft}^2} \times \frac{1}{144} = 0.271 \text{ psi}$$

per 1 ft width = 3.9 k/ft = w

$$M = wL^2/2 = (3.9) \left( \frac{1}{2}(8 - 20) \right)^2 / 2 = 19.55 \text{ k-ft}$$

$$\phi V_c = \phi (1 \sqrt{f_c}) = 0.75(1) \sqrt{4000} = 189.7 \text{ psi} = 0.190 \text{ ksi}$$

$$d^2 (V_c + \frac{q}{4}) + d (V_c + \frac{q}{2}) w - \frac{q}{4} (BL - w^2) = 0$$

$$d^2 (190 + \frac{27.1}{4}) + d (190 + \frac{27.1}{2}) 20 - \frac{27.1}{4} (8 \times 8 - 20^2) = 0$$

$$197d^2 + 4071d = 59728$$

$$d \geq 9.9$$

use #5s db = 5/8

$$h = d + c_c + d_b$$

$$= 9.9 + 3 + 5/8 = 13.5" \rightarrow \text{use } 14" \text{ depth } (1'2")$$

$$\therefore d = 14 - 3 - 5/8 = 10.375" \quad j_d = 2(10) + 2(8 \times 12) = 232"$$

$$\therefore V_c \leq \min \begin{cases} 0.75(1) \sqrt{4000} \cdot 232 \cdot 10.375 = 457 > \phi V_c \text{ above ok.} \\ 0.75(2+2) \sqrt{4000} \cdot 232 \cdot 10.375 = \checkmark \\ \frac{48(10.375) + 2}{232} \sqrt{4000} \cdot 232 \cdot 10.375 = 577 \end{cases}$$

Design for flexure:

$$M = \frac{wL^2}{2} = \frac{(3.9 \text{ k/ft})(3.17)^2}{2} = 19.6 \text{ k-ft}$$

$$l = 4L - \frac{10}{2} = 3.17$$

$$a = \frac{A_s f_y}{0.85 f_c b} = \frac{A_s 60}{0.85(4)(14)} = 1.48 A_s$$

$$M_u \leq \phi M_n = \phi A_s f_y (d - a/2) = 0.9 A_s 60 (10.375 - 1.48 A_s / 2)$$

$$19.6 \times 12 = 235.2 = 560.25 A_s - 39.96 A_s^2$$

$$A_s \geq 4.3 \text{ in}^2$$

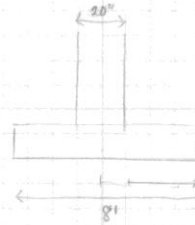

Findings 2

try #5s  $A_{s2} = .91 \frac{\text{in}^2}{\text{ft}} \left( \frac{16''}{8''} \right) = .47 \text{ in}^2/\text{ft width}$  ∴ #5s @ 8"

ck ductility  
 $c = a/\beta \Rightarrow a = 148(.47) = 3.15 \rightarrow c = 3.70''$   
 $\epsilon_s = .003 \Rightarrow (10.35 - 3.70) / 3.70 = .0054 > .005 \therefore \phi = 0.9 \checkmark \text{ok}$

uses (10) #5s  $A_s = .44 \text{ in}^2$  per 1 #6

or, can use (8) #6s @ 16" o.c.

Bearing ck:  
 $\phi B_n = 0.65 (0.85) 4 \text{ ksi } 20 \times 20 = 884 \text{ k} > P_u = 250.2 \text{ k} \checkmark \text{ok}$

∴ Col Footing at 8'x8' footing  
with #6s @ 16" o.c both direction

Founders

Strip footing  
 wall along column line F.

use 12" CMU wall

Size by ASD:  
 $P = 11.4 \text{ klf}$

$\frac{12.4 \times 1}{1' \times B} \leq 3 \rightarrow B = 4.1' \text{ } \boxed{4.5' \text{ wide}}$

by LRFD:  
 $P_u = 18.9 \text{ klf}$   
 $\therefore q = \frac{18.9}{4.5} = 4.2 \text{ k}$   
 $M_u = q l^2 / 2 = 4.2 (1.83)^2 / 2 = 7.03 \text{ k-ft / ft width}$   
 $\phi M_n = 0.55 (5 \sqrt{4000}) (12 h^2 / 6) \geq 7.03 \text{ k-ft} \times 1000 \times 12"$   
 $h \geq 15.6 \rightarrow 16" \text{ depth}$

ck. shear:  
 @ quarter pt.  $l = 1.83 + 2.5/2 = 2.04'$   
 $\phi V_n = 0.55 (\frac{4}{3}) \sqrt{4000} \cdot 10 \cdot 16 \geq q \times l = 4.2 \times 1000 \times 2.04$   
 $7420.8 \geq 8568 \text{ lbs.}$   
 try  $d = 20"$   $\phi V_n = 9276 \text{ lbs} \geq 8568 \text{ lbs}$  ✓ ok

T9S reinf by ACI code ch7  
 $\rho_{min} = .0018 = \frac{A_s}{4.5' \times 20" \times 12} \rightarrow A_s = 1.94 \text{ in}^2$   
 use (7) #5s spaced evenly

## Appendix E RAM Model & Building Properties

### Center of Mass & Center of Rigidity

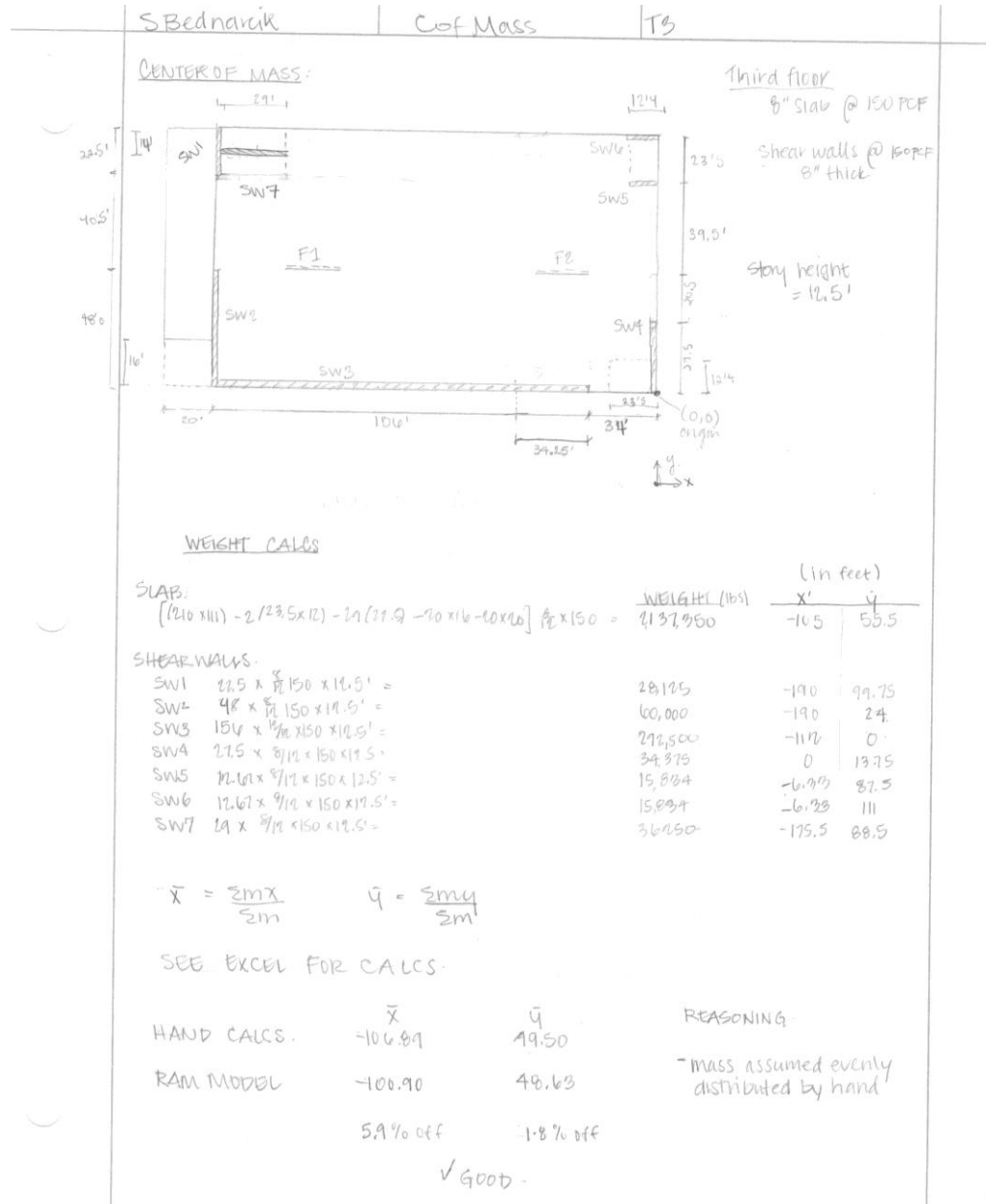

Center of Mass Hand Calculations - 3rd Floor					
System	Mass	x (ft)	y (ft)	m*x	m*y
Slab	2137350	-105	55.5	-224421750	118622925
SW1	28125	-190	99.75	-5343750	2805468.75
SW2	60000	-190	24	-11400000	1440000
SW3	292500	-112	0	-32760000	0
SW4	34375	0	13.75	0	472656.25
SW5	15834	6.33	87.5	100229.22	1385475
SW6	15834	6.33	111	100229.22	1757574
SW7	36250	-175.5	88.5	-6361875	3208125
Sums	2620268			-280086916.6	129692224
		xbar=	-106.89		
		ybar=	49.50		

Periods of Vibration	
Tx=	0.8072
Ty=	1.1262
Ttors=	0.9004

## Load Transfer

Level	Direction	Frame	Horiz Force (k)	%V	Sum Check	% Error	Stiffness, X	Stiffness, Y
Roof	x	SW3	334.08	35.60			0.68	
		SW5	30.23	3.22			0.05	
		SW6	33.09	3.53			0.05	
		SW7	494.05	52.64			0.79	
		F1	43.86	4.67			0.07	
		F2	3.19	0.34	938.50	6.15	0.01	
	y	SW1	668.06	66.81				1.00
		SW4	316.26	31.63	1000.01	0.00		0.47
Mech Roof	x	SW3	352.47	37.99			0.72	
		SW5	30.23	3.26			0.06	
		SW6	33.09	3.57			0.07	
		SW7	491.03	52.92			1.00	
		F1	20.96	2.26			0.04	
		F2	0.07	0.01	927.85	7.21	0.00	
	y	SW1	668.05	66.80				1.00
		SW2	69.43	6.94				0.10
		SW4	316.26	31.62	1000.04	0.00		0.47
4th	x	SW3	406.43	41.98			0.91	
		SW5	30.23	3.12			0.07	
		SW6	33.09	3.42			0.07	
		SW7	447.56	46.23			1.00	
		F1	22.20	2.29			0.05	
		F2	28.70	2.96	968.21	3.18	0.06	
	y	SW1	814.09	80.96				1.00
		SW2	69.43	6.90				0.09
		SW4	108.61	10.80	1005.53	-0.55		0.13
3rd	x	SW3	494.32	49.90			1.00	
		SW5	-12.29	-1.24			-0.02	
		SW6	-6.10	-0.62			-0.01	
		SW7	476.62	48.11			0.96	
		F1	19.63	1.98			0.04	
		F2	18.40	1.86	990.59	0.94	0.04	
	y	SW1	149.66	14.97				0.20
		SW2	731.65	73.17				1.00
		SW4	118.17	11.82	1000.00	0.00		0.16
2nd	x	SW3	563.76	56.38			1.00	
		SW5	50.66	5.07			0.18	
		SW6	61.63	6.16			0.08	
		SW7	279.52	27.95			0.38	
		F1	61.41	6.14			0.08	
		F2	50.15	5.02	1067.13	-6.71	0.07	
	y	SW1	46.44	4.64				0.06
		SW2	731.65	73.17				1.00
		SW4	231.31	23.13	1006.33	-0.63		0.32
Ground	x	SW3	563.76	56.38			1.00	
		SW5	50.66	5.07			0.09	
		SW6	61.63	6.16			0.11	
		SW7	279.52	27.95			0.50	
		F1	33.61	3.36			0.06	
		F2	31.38	3.14	1020.55	-2.06	0.06	
	y	SW1	40.00	4.00				0.05
		SW2	731.65	73.17				1.00
		SW4	231.31	23.13	1001.58	-0.16		0.32
V (total story shear)=					1000		k	Acting at Roof

Relative Stiffness check and torsional shear calculations:

Relative Stiffnesses			
Floor	Shear Wall	R. S. X	R. S. Y
Roof	SW1	0	0.26
	SW2	0.09	0.25
	SW3	-0.03	0.12
	SW4	-0.05	0.36
	SW5	0.61	0
	SW6	0.4	0
	SW7	0	0
Mech Rf	SW1	0	0.27
	SW2	0.06	0.26
	SW3	-0.03	0.12
	SW4	-0.05	0.36
	SW5	0.69	-0.01
	SW6	0.4	0
	SW7	-0.07	0.01
Fourth	SW1	0.19	0.26
	SW2	0.06	0.26
	SW3	-0.03	0.12
	SW4	-0.23	0.37
	SW5	0.25	0.02
	SW6	0.13	0.01
	SW7	0.64	-0.03
Third	SW1	0.11	0.26
	SW2	0.12	0.26
	SW3	-0.06	0.13
	SW4	-0.18	0.36
	SW5	0.31	0.01
	SW6	0.15	0.01
	SW7	0.57	-0.02
Second	SW1	0.1	0.29
	SW2	0.1	0.24
	SW3	-0.06	0.16
	SW4	-0.14	0.32
	SW5	0.31	0.01
	SW6	0.26	0.01
	SW7	0.45	-0.02

Roof	Shear Wall	Direct Shear		Torsional Shear						Total Shear		% off	
		x		ki	F	5%	M	di	$ki \cdot di^2$	$\sum ki \cdot di^2$	$F_i = M_i \cdot k_i \cdot di / (\sum k_i \cdot di^2)$		Hand Calcs
	SW1	0	232.54	0.26	232.54	9.5	2209.13	-90.84	2145.50	-5.83	-5.83	-5.55	-5.03
	SW2	20.9286	232.54	0.25	232.54	9.5	2209.13	90.84	2062.98	5.60	26.61	26.61	0.29
	SW3	-6.9762	232.54	0.12	232.54	9.5	2209.13	86.86	905.36	2.57	-7.01	-7.01	37.18
	SW4	-11.627	232.54	0.36	232.54	9.5	2209.13	99.16	3539.77	8.81	-12.99	-12.99	78.32
	SW5	141.8494	232.54	0.61	232.54	5.55	1290.60	17.16	179.62	1.51	151.9	151.9	5.62
	SW6	93.016	232.54	0.4	232.54	5.55	1290.60	17.16	117.79	0.99	94.01	94.01	4.40
	SW7	0	232.54	0	232.54	5.55	1290.60	66.83	0.00	8951	0.00	0	0.00
Input:													
Load													
	232.54												



Torsion

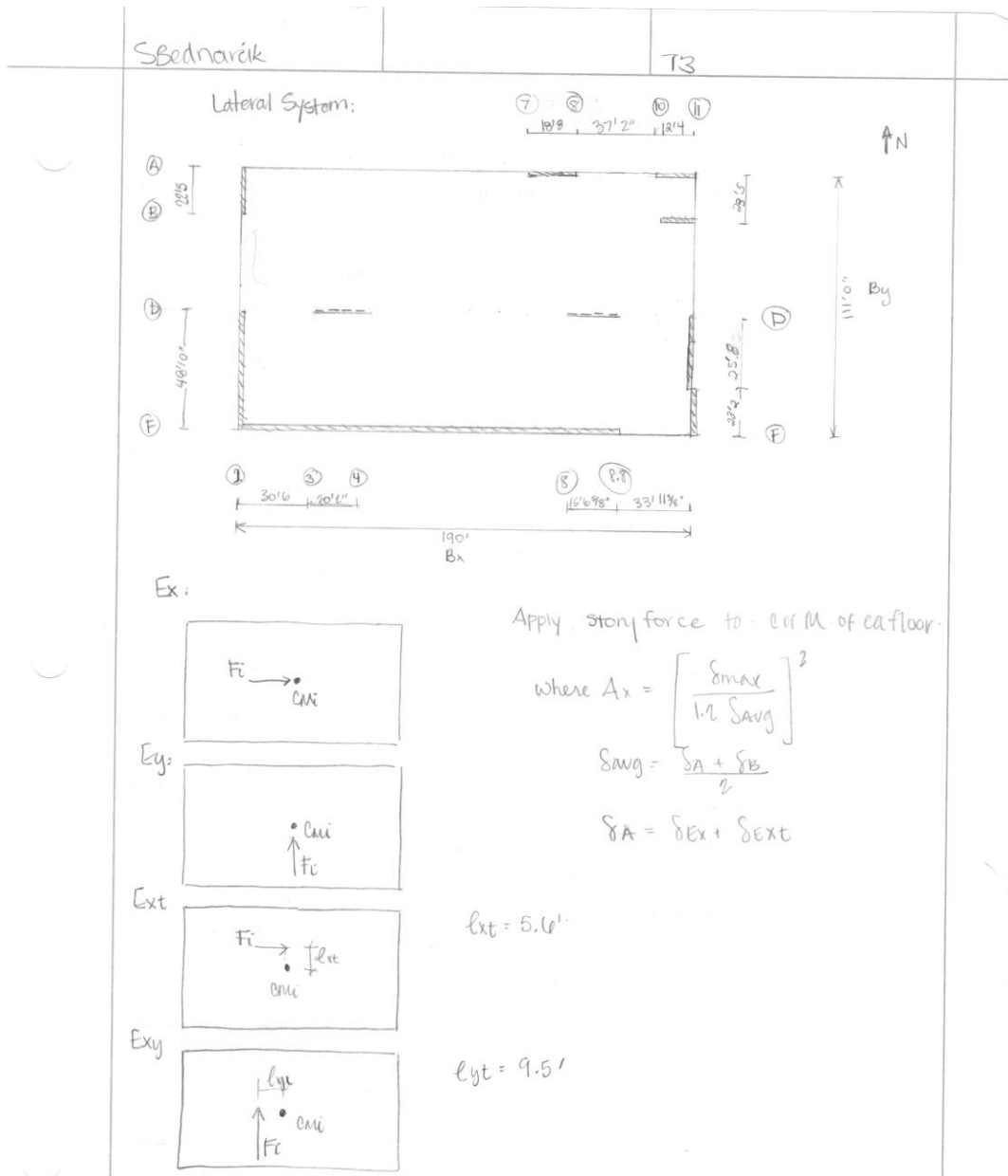

Apply story force to center of mass of each floor.

$$\text{where } A_x = \left[ \frac{\delta_{\text{max}}}{1.2 \delta_{\text{avg}}} \right]^2$$

$$\delta_{\text{avg}} = \frac{\delta_A + \delta_B}{2}$$

$$\delta_A = \delta_{\text{Ex}} + \delta_{\text{Ext}}$$

$$l_{\text{xt}} = 5.6'$$

$$l_{\text{yt}} = 9.5'$$

Calculation of Amplification Factor:										
X Direction	Level	δ1			δ2			δavg	Ax	Irregularity Type by Table 12.3-1
		δ1 (Ex)	δ1 (Ext)	δ1	δ2 (Ex)	δ2 (Ext)	δ2			
X Direction	Roof	0.189	0.206	0.395	0.188	0.206	0.394	0.395	1.0	1a
	Mech Roof	0.141	0.154	0.295	0.141	0.154	0.295	0.295	1.0	1a
	4th	0.124	0.136	0.260	0.124	0.135	0.259	0.260	1.0	1a
	3rd	0.079	0.083	0.162	0.079	0.086	0.165	0.164	1.0	1a
	2nd	0.027	0.030	0.057	0.027	0.030	0.057	0.057	1.0	1a
Y Direction	Level	δ1			δ2			δavg	Ay	Irregularity Type by Table 12.3-1
		δ1 (Ey)	δ1 (Eyt)	δ1	δ2 (Ey)	δ2 (Eyt)	δ2			
Y Direction	Roof	0.345	0.337	0.682	0.843	0.900	1.743	1.212	1.4	1b
	Mech Roof	0.250	0.245	0.495	0.622	0.664	1.286	0.891	1.4	1b
	4th	0.215	0.211	0.426	0.542	0.579	1.121	0.773	1.5	1b
	3rd	0.124	0.121	0.245	0.334	0.357	0.691	0.468	1.5	1b
	2nd	0.035	0.034	0.069	0.104	0.111	0.215	0.142	1.6	1b

## Appendix F Lateral Redesign

### Applied Building Loads

Weight of Building	Area	PSF	Load (lbs)	Story Weight (lbs)
CMU	4310	91	392210	
Curtain Wall	2160	20	43200	
Concrete Shear Walls	9610	100	961000	
<b>Floor 2</b>	<b>12090</b>	<b>67</b>	<b>810030</b>	<b>2206.44</b>
CMU	9140	91	831740	
Curtain Wall	2160	20	43200	
Concrete Shear Walls	9610	100	961000	
<b>Floor 3</b>	<b>21060</b>	<b>105</b>	<b>2211300</b>	<b>4047240</b>
CMU	5920	91	538720	
Curtain Wall	2300	20	46000	
Concrete Shear Walls	6030	100	603000	
<b>Floor 4</b>	<b>21060</b>	<b>67</b>	<b>1411020</b>	<b>2598740</b>
<b>Mechanical (RTU)</b>			<b>35934</b>	<b>35934</b>
CMU	4520	91	411320	
Curtain Wall	3500	20	70000	
Concrete Shear Walls	8530	100	853000	
Roof	17460	80	1396800	2731120
Columns	1870	70	130900	130900
<b>Total Weight (lbs)</b>				<b>9546140.44</b>
			<b>(k)</b>	<b>9546</b>

Calculation of Amplification Factor:									
X Direction					Y Direction				
$\delta 1$	$\delta 1 (Ex+)$	$\delta 1 (Ex-)$	$\delta 2$	$\Delta 2$	$\delta avg$	$\delta max$	$Ax = (\delta max / (1.2 * \delta avg))^2$	Irregularity Type by Table 12.3-1	
0.312	0.758	0.766	0.766	0.167	0.813	0.861	N/A	N/A	N/A
0.011	0.599	0.593	0.599	-0.005	0.574	0.599	N/A	N/A	N/A
0.174	0.604	0.585	0.604	0.285	0.571	0.604	N/A	N/A	N/A
0.254	0.315	0.319	0.319	0.210	0.341	0.363	N/A	N/A	N/A
0.109	0.109	0.105	0.109	0.109	0.109	0.109	N/A	N/A	N/A
$\delta 1$	$\delta 1 (Ey+)$	$\delta 1 (Ey-)$	$\delta 2$	$\Delta 2$	$\delta avg$	$\delta max$	$Ay = (\delta max / (1.2 * \delta avg))^2$	Irregularity Type by Table 12.3-1	
-0.048	0.374	0.452	0.452	0.103	0.334	0.452	1.3	1a	1a
0.109	0.289	0.348	0.348	0.025	0.307	0.348	N/A	N/A	N/A
0.053	0.266	0.323	0.323	0.123	0.240	0.323	1.3	1a	1a
0.069	0.165	0.200	0.200	0.137	0.152	0.200	1.2	1a	1a
0.034	0.052	0.063	0.063	0.063	0.049	0.063	1.2	1a	1a

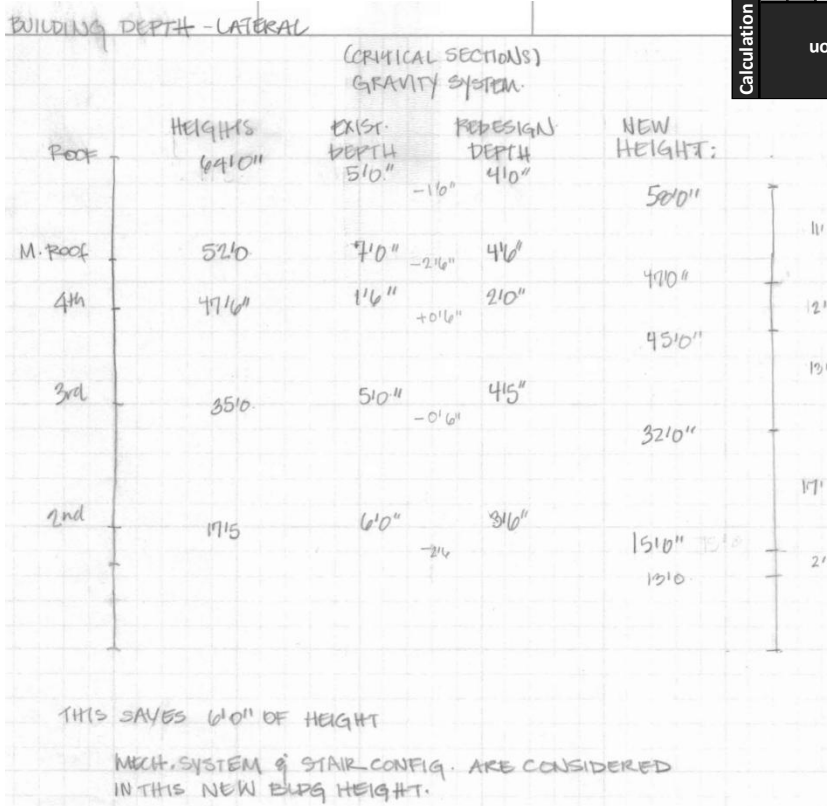

LATERAL - WIND

BEDNARCİK

1

USING ASCE 7-05 Ch 6, Method 2:

Bldg LAYOUT:

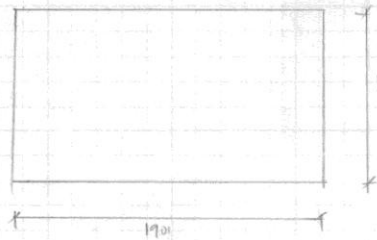

New roof height

Elevation = 58'

Assumed flat roof  
∴ mean roof ht,  $h = 58'$

FOR A N-S WIND:

L = 111 ft  
B = 190 ft

E-W

L = 190 ft  
B = 111 ft

§ 6.5.3 Design Procedures

1. Wind speed  $V = 90$  mph (Fig 6-1)  
Directionality Factor,  $K_d = 0.85$  (Table 6-4)
2. Importance Factor  $I = 1.15$  (Tab 6-1)  
Category III (Tab 1-1)
3. Exposure Category:

§ 6.5.6 Exposure B

Vel. Pressure Exp Coeff. (Table 6-2)

Case 2, EXP B

Interpolate  $z = 50 \begin{cases} .81 \\ .85 \end{cases} \rightarrow$  at  $z = 58'$   $K_z = .84$

4. Topographic factor,  $K_{zt}$

§ 6.5.7  $K_{zt} = 1.0$

Other  $K_z$  values on Excel

5. Gust Effect Factor,  $G$  or  $G_f$

§ 6.5.8

rigid or flexible:

$$n_1 = \frac{100}{58} = 1.72$$

(C 6-17)

$n_1 = \frac{75}{58} = 1.29$  ∴ rigid building

(C 6-18)

$n_1 =$  natural bldg freq.

→ use § 6.5.8.1

$$G = 1.15 \left( \frac{1 + 1.7 G_u I_z G}{1 + 1.7 G_u I_z} \right)$$

$$G_u = G_v = 3.9$$

from table 6-2  $d = 7.0$   $Z_g = 1200$   $R = 1/4.0$   $S = 0.46$   
 $c = 0.3$   $X = 320$   $E = 1/3.0$

$$I_z = c \left( \frac{33}{Z} \right)^{1/6} = 0.90 \left( \frac{33}{34.8} \right)^{1/6} = .947 \quad Z = \max \left\{ \begin{matrix} 1.6(58) \\ 50 \end{matrix} \right\} = 34.8$$

N-S

$$Q = \sqrt{1 + 0.63 \left(\frac{B+H}{L}\right)^2} \cdot 1.65$$

$$\therefore L_A = L \left(\frac{Z}{30}\right)^E = 320 \left(\frac{58}{30}\right)^{1.3} = 386.18$$

$R_{NS} = .82$

$$G = .925 \left( \frac{(1 + 1.7(3.4)(386.18)(.82))}{1 + 1.7(3.4)(386.18)} \right)$$

$= .76$

6. Fully enclosed.  
7. Internal Pressure  $G_{Cpi} = \pm 0.19$  (Fig 6-5)  
8. Ext. Pressure Coeff

$L/B = .58$

Walls:

0.8	(q <sub>2</sub> ) Windward	0.8
-0.5	(q <sub>1</sub> ) Leeward	-0.34
-0.7	(q <sub>3</sub> ) Side	-0.7

Roof Pressures: (q<sub>h</sub>)

$\theta = 0^\circ$

$h/L = 58/111 = .52$		$h/L = 58/160 = .36$	
Interpolated			
-0.88, -0.18	0 to 1/2 = .29	-0.9, -0.18	
-0.89, -0.18	1/2 to h = .29 to .58	-0.9, -0.18	
-0.51, -0.18	h to 2h = .58 to 1.16	-0.5, -0.18	
-0.32, -0.18	>2h = >1.16	-0.3, -0.18	

Roof area = 190x111  $\geq 1000$  SF  $\therefore$  Reduction factor = 0.8

9. Velocity Pressure  $q_z, q_h$  § 6.5.10

at  $h=58'$

$$q_z = 0.00256 K_z K_{zt} K_d V^2 I$$

$$= 0.00256 (0.85)(0.84)(90^\circ)(1.15)$$

$$= 17.08$$

§ 6.5.9.4	$K_d = 0.85$
§ 6.5.6.6	$K_{zt} = 0.84$ * varies per height
§ 6.5.7.2	$K_{zt} = 1.0$

\* others on excel spreadsheet

10. design wind load

MWFRS

$$P = q G C_p - q_i (G C_{pi})$$

$q = q_z$  windward  
 $q_h$  leeward, side, roof  
 $q_i = q_h$  all

see excel for further calcs.

E-W

$$L_A = 386.18$$

$R_{EW} = .85$

$$G = .925 \left( \frac{(1 + 1.7(3.4)(386.18)(.85))}{1 + 1.7(3.4)(386.18)} \right)$$

$= .79$

$L/B = 1.71$

Walls:

0.8	(q <sub>2</sub> ) Windward	0.8
-0.5	(q <sub>1</sub> ) Leeward	-0.34
-0.7	(q <sub>3</sub> ) Side	-0.7

Roof Pressures: (q<sub>h</sub>)

$\theta = 0^\circ$

$h/L = 58/111 = .52$		$h/L = 58/160 = .36$	
Interpolated			
-0.88, -0.18	0 to 1/2 = .29	-0.9, -0.18	
-0.89, -0.18	1/2 to h = .29 to .58	-0.9, -0.18	
-0.51, -0.18	h to 2h = .58 to 1.16	-0.5, -0.18	
-0.32, -0.18	>2h = >1.16	-0.3, -0.18	

Roof area = 190x111  $\geq 1000$  SF  $\therefore$  Reduction factor = 0.8

9. Velocity Pressure  $q_z, q_h$  § 6.5.10

at  $h=58'$

$$q_z = 0.00256 K_z K_{zt} K_d V^2 I$$

$$= 0.00256 (0.85)(0.84)(90^\circ)(1.15)$$

$$= 17.08$$

§ 6.5.9.4	$K_d = 0.85$
§ 6.5.6.6	$K_{zt} = 0.84$ * varies per height
§ 6.5.7.2	$K_{zt} = 1.0$

\* others on excel spreadsheet

10. design wind load

MWFRS

$$P = q G C_p - q_i (G C_{pi})$$

$q = q_z$  windward  
 $q_h$  leeward, side, roof  
 $q_i = q_h$  all

see excel for further calcs.

WIND :

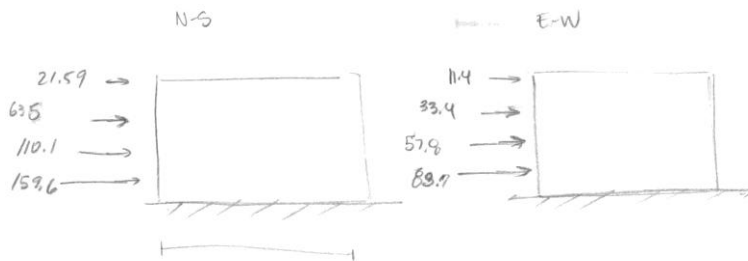

Look at critical sections :

## LATERAL - SEISMIC

USING ASCE 7-05 §11.4  
FROM GPEOTECHE REPORT

$S_s = 0.26$   
 $S_1 = 0.06$   
Site Class D

$F_a = 1.6$  (Table 11.4-1)

$F_v = 2.4$  (Table 11.4-2)

$$S_{M2} = F_a S_s = 1.6(0.26) = .416$$

$$S_{M1} = F_v S_1 = 2.4(0.06) = .144$$

$$\rightarrow S_{S2} = \frac{2}{3} S_{M2} = .277$$

$$S_{S1} = \frac{2}{3} S_{M1} = .096$$

$$S_a = S_{S2} (0.4 + 0.6 T/T_0)$$

$$T_0 = 0.1 S_{S1} / S_{S2} = 0.2 (0.096) / .277 = 0.0693$$

$$T_0 = S_{S1} / S_{S2} = 0.096 / 0.277 = .347$$

FINDING  $T$ , fundamental period of bldg.

§12.8.1

$$T \leq C_u T_a$$

$$T_a = C_u h_n^x = (0.02)(58)^{.75} = .420$$

$$C_u = 1.7$$

(Table 12.8-2)

$$\rightarrow T = 1.7 (.420) = .715$$

$$\therefore S_a = .277 (0.4 + 0.6 (.715 / 0.0693)) = 1.8244$$

$$C_s = \frac{S_{S2}}{R/I} = \frac{.277}{4/1.5} = .1029$$

where  $R = 4$  Table 2.1

$I = 1.25$  Table 11.5-1 Occ Cat III

$$T_c = 6 \text{ (Fig 22-19)}$$

$$T < T_c \therefore C_s = .1029 \leq \frac{S_{S1}}{T/(R/I)} = \frac{.096}{.715(4/1.25)} = .042$$

by §12.8.1-1 (12.8.1-2)

$$C_s = .1029$$

$\therefore$  can be reduced to

$$\text{by §12.8.1.1} = 0.042$$

values confirmed with  
"Loads & Applied Forces"

§10.10.4

walls uncracked  $0.70 I_g$   
cracked  $0.35 I_g$

2

Building Weight: Example

Roof: slab 15 PSF  
mech 7 PSF  
6" ← framing walls 75 PSF

Area =  $111 \times 205 - (30 + 22 \times 4) 50$   
=  $16855 \text{ ft}^2$

= 498 k  
= 2959 k

walls:  $[7 \times 30.5' + 2 \times 23.5 + 50 + 40 + 4 \times 12] \times 150 \times \frac{16}{12} \times 7.5' = 498 \text{ k}$

In comparison,  
Hand Calc = 3144 k      RAM = 3167 k  
off by 0.8% okay. ∴ RAM will calc other loadings correctly.

§12.8.3

$F_x = C_{vx} V$  { force per level } where  $w_x = \text{weight at level}$   
 $h_x = \text{height from base to level}$   
 $k = 1 \quad T < 0.5$   
 $k = 2 \quad T > 2.5$

$C_{vx} = \frac{w_x h_x^k}{\sum w_i h_i^k}$

building period  $T = .715 \rightarrow k = 1.11$

Story shear =  $V_x = \sum F_x$        $V = C_v W$

§12.8.4. Torsion

Amplification -4.3       $A_x = \left( \frac{\delta_{max}}{1.2 \delta_{avg}} \right)^2$

using nodes at:

Roof, 3 <sup>rd</sup>	NE	(-10.0, 108.85)
	SW	(-187.3, 0)
Mech Rf	SE	(-68.2, 0.2)
	NW	(-187.3, 48.9)
4 <sup>th</sup> , 2 <sup>nd</sup>	SE	(0, 10.55)
	NW	(-188.3, 109.2)

using interstory drift

Design Results

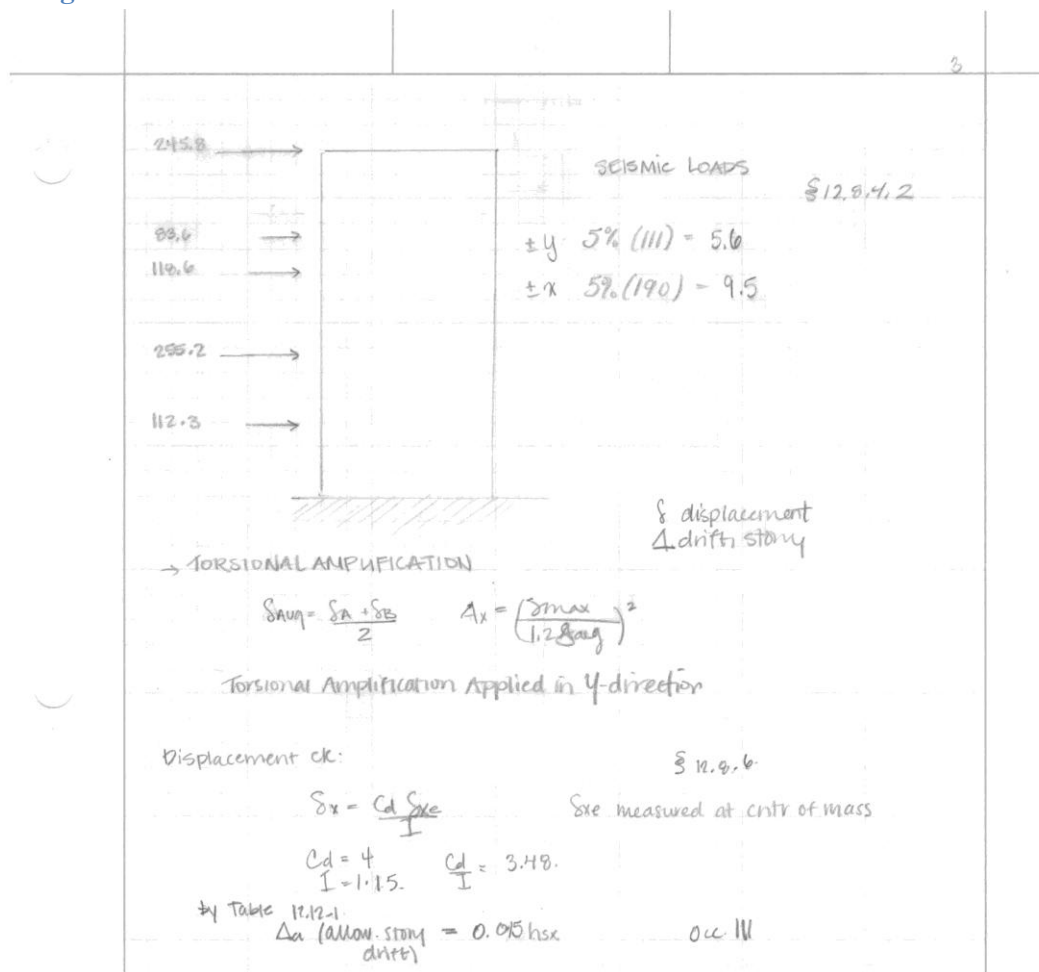

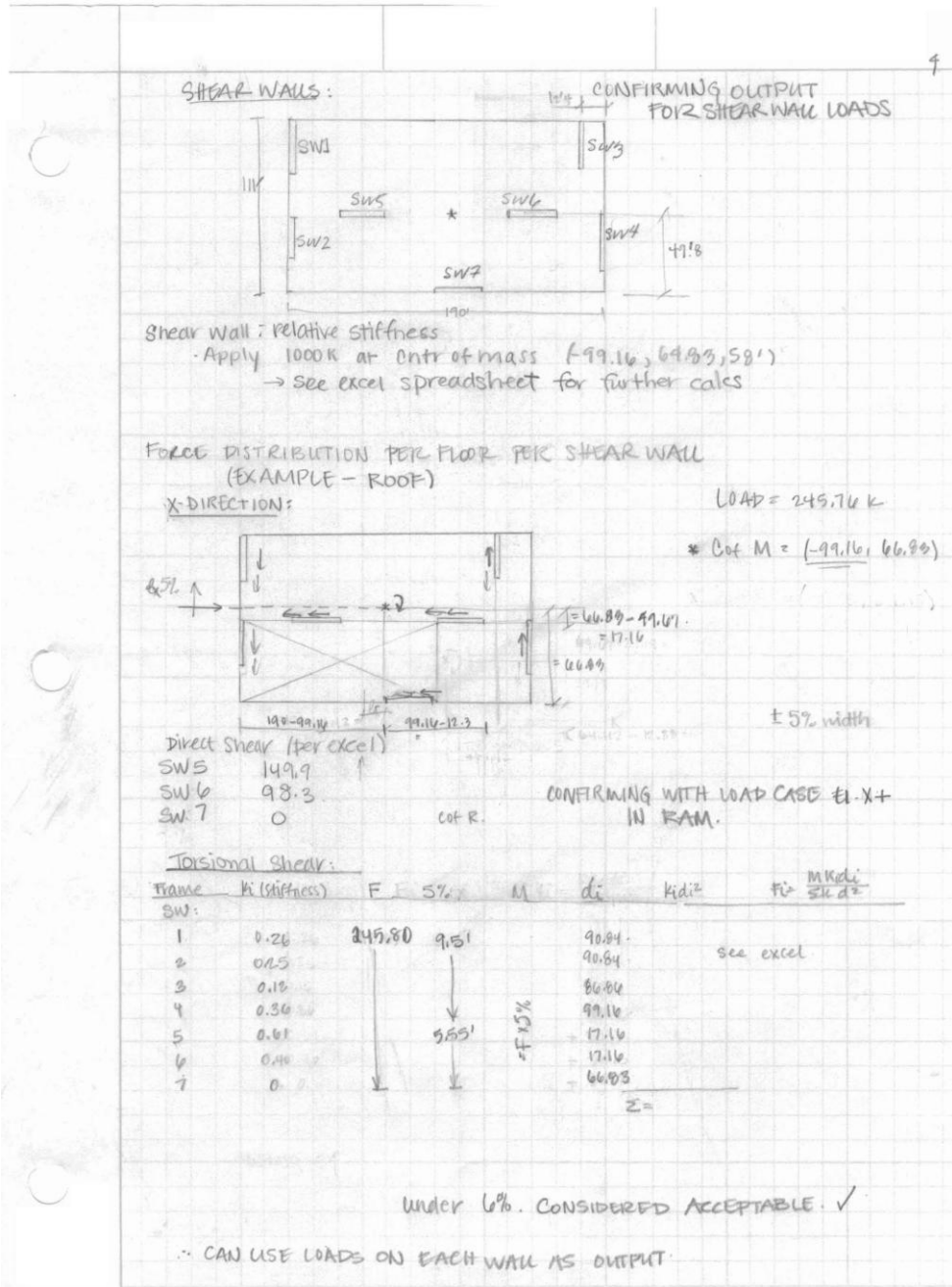



5

CONSIDER SHEAR WALL 1:

-Not required to be designed by seismic provisions as Spc by §21.1.1.5, -7

wall thickness = 8" = h

See excel for distribution calcs.

a) Slender or short

$$\frac{h_w}{l_w} = \frac{581}{25.8} = 2.25 \geq 2 \therefore \text{design by Ch 10 \& 11 ACI}$$

See excel for deflection check  
See Ch 11 - walls - shear load  
See Ch 14 - walls - of ACI 318-11 axial load

base Shear = 922.14 k =  $V_u$

Mov = 25,443.4 k-ft =  $M_u$

$l = 25.8$

$f_c = 4000$  ksi

§ 11.9.1 Shear Str.

$$d = 0.8 l_w = 0.8 (25.8) = 20.64' \times 12'' = 247.7''$$

§ 11.9.1

$$V_c = 3.3 \lambda \sqrt{f_c} h d + \frac{N_u d}{4 l_w}$$

where  $N_u = +12(186.37) + 116(164.46) = 1206.78$  k

$$= 3.3 \sqrt{4000} (1) (247.7) + \frac{1206.78 \cdot 247.7}{4 (25.8 \times 12'')} = 654,903 \text{ lbs} = \boxed{655 \text{ kips}}$$

= min

$$= \frac{M_u}{V_u} - \frac{l_w}{2} = \frac{25443}{922} - \frac{25.8 \times 12}{2} = -127.3 < 0 \therefore \text{doesn't apply.}$$

$\phi V_c = 0.75 (655) = 491.3 > V_u \therefore$  req'd  $V_s$  reinf.

§ 11.9.8  $V_u = 922.1 \text{ k} \geq 0.5 \phi V_c = 0.5 (0.75) (655) = 245.6 \text{ k}$

§ 11.9.9

$$V_s = \frac{A_v f_y d}{s} = \frac{A_v (60,000) (20.64)}{s} = \frac{A_v}{s} 1.238E6$$

by eq. 11.1 and 11.2

$$V_s = \left( \frac{V_u}{\phi} - V_c \right) = \left( \frac{922.1}{0.75} - 655 \right) = 574.5$$

$$\frac{A_v}{s} (1.238E6) \geq 574.5 \times 1000 \rightarrow \frac{A_v}{s} \geq 464.4$$

$S_{max} = \min \begin{cases} l_w/5 = 25.8 \times 12/5 = 61.9'' \\ 3h = 3(8) = 24'' \\ 18'' \end{cases}$  ← controlling

$S_{max} = \min \begin{cases} l_w/3 \\ 3h = 24'' \\ 18'' \end{cases}$  ← controls

6

min reinf:  $h = 8" =$

horiz.  $\rho_t = \frac{A_v}{h \cdot S_t} = .125 \frac{A_v}{S_t} > .0025$

vert.  $\rho_e = \frac{A_v}{h \cdot S_e} = .125 \frac{A_v}{S_e} > \max \left\{ \begin{array}{l} .0025 \\ .0025 + .5 \left( 2.5 - \frac{h_w}{l_w} \right) (\rho_t - .0025) \end{array} \right.$

use min  $(.125) \frac{2(.2)}{12" o.c.} = .004 > .0025 \checkmark$  for  $\rho_t$

$\rho_t = \frac{.125(2)(.31)}{12"} = .006 > \left\{ \begin{array}{l} .0025 \\ .0025 + .5 \left( 2.5 - \frac{58 \times 2}{25.8 \times 18} \right) (.004 - .0025) \end{array} \right.$

$= .0027$

OKAY by min

req'd for str:  $A_v = \frac{3}{f_y d} (574.5) \quad \text{try } 10" o.c.$

$= \frac{10" (574.5)}{60 \times 247.7} = .387 \text{ in}^2 \rightarrow \text{use } (2) \#4s @ A_s = 10 \text{ in}^2$

# of layers req'd:

2 if  $V_u > 2 A_c v \sqrt{f'_c} = 2 (8" \times 25.8 \times 12) \sqrt{4000} = 313.2 \text{ k} \checkmark$  2 layers

ck:  $\phi V_u \geq V_u$

$\phi (N_c + V_s) = .75 (655 + \frac{4}{10"} (60) (247.7)) = 937. \text{ k} > 922 \text{ k}$

$\therefore$  use: (2) #4s @ 10" o.c. in 2 layers horiz. reinf. (shear)

Moment Strength

$M_u = 25.413 \text{ k-ft}$   
 $N_u = 1206.8 \text{ k}$

following procedure in ch19 of Wight & McGregor in allowance of ACI 318-11

ck:  $\phi M_n \geq M_u$

$M_n = T \left( d - \frac{a}{2} \right) + N_u \left( \frac{l_w - e}{2} \right)$

recall:  $l_w = 25.8 \times 12 = 309.6$

$a = \frac{T + N_u}{.85 f'_c b}$

$T = A_s f_y = A_s 60$

$d = l_w - (\beta + 3/4) = 298.6" \quad \text{estimate}$

$b = 8"$

$A_s = .91 \text{ in}^2$

7

$$a = \frac{60A_s + 1206.8}{.85(4)(8)} = \frac{60A_s + 1206.8}{27.2} = 2.21A_s + 44.4 \quad \text{using } f_c = 4 \text{ ksi} \\ \beta = 0.85$$

$$M_n = 60A_s(298.6 - \frac{1}{2}(2.21A_s + 44.4)) + 1206.8(309.6 - (2.21A_s + 44.4)) \frac{1}{2} \\ = -26.3A_s^2 + 14650.5A_s + 160022$$

$\phi M_n$  where  $\phi = 0.9$  for flexure  $M_u = 25443 \text{ k}\cdot\text{ft} \times 12''$

→ solving for  $A_s = 10.41 \text{ in}^2$

use (10) #10s  $A_s \text{ provided} = 10(1.27) = 12.7 \text{ in}^2$

this provides enough str for tension reinf

confirm:  $\phi M_n > M_u$

$$0.9 \left[ 60(12.7) \left( 294.6 - \frac{72.4}{2} \right) + 1206.8 \left( \frac{309.6 - 72.4}{2} \right) \right]$$

$$a = \frac{60(12.7) + 1206.8}{27.2} = 72.4$$

$$= 306 \text{ k}\cdot\text{in} > 25443 \text{ k}\cdot\text{ft} \times 12 = 205 \text{ k}\cdot\text{in} \quad \text{✓ okay}$$

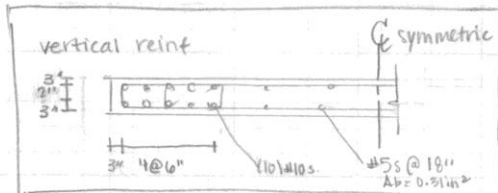
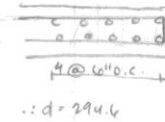

min sp btwn bars = max  $\left\{ \begin{matrix} 1'' \\ db = 1.27 \end{matrix} \right\}$  ✓ ok

$$A_{s \text{ min}} = \frac{2\sqrt{f_c}}{f_y} b w \cdot d = \frac{2\sqrt{4800}}{60000} \cdot 8 \cdot 294.6 = 7.45 < 12.7 \text{ in}^2 \text{ ok } \checkmark$$

$$P_{st} = .0018 = \frac{A_s}{A_c} \rightarrow A_s = (0.018)(6'' \times 25.0 \text{ ft} \times 12) = 3.34 \text{ in}^2$$

or .13 in<sup>2</sup>/ft length

Σ 7.12

∴ #5 @ 18'' ok for S+T.

## Appendix G Breadth – Acoustics

### Reverberation Times

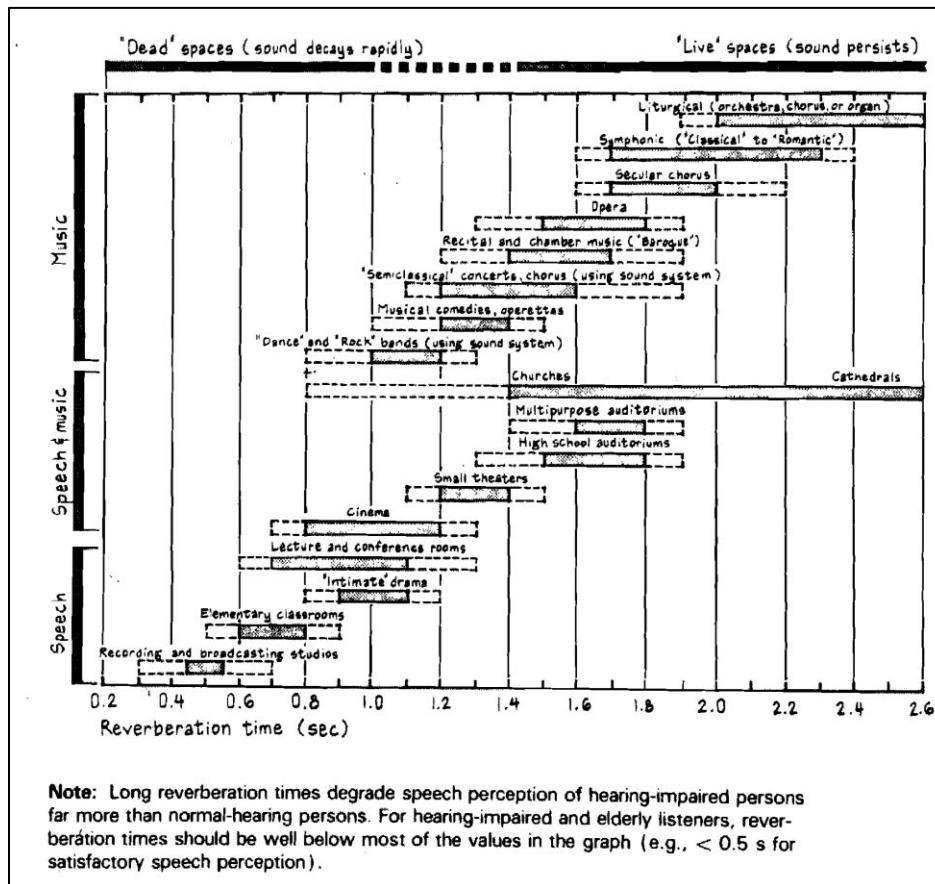

- Optimum  $T_{60}$  at 500 Hz and 1 kHz for different room usages (empirically derived):

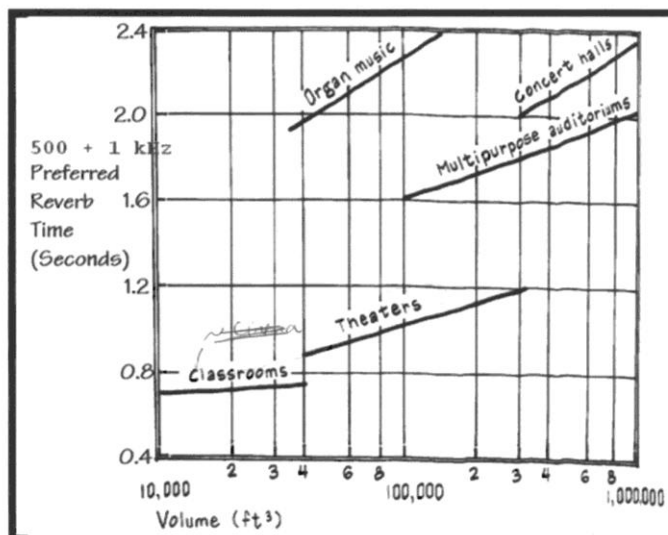

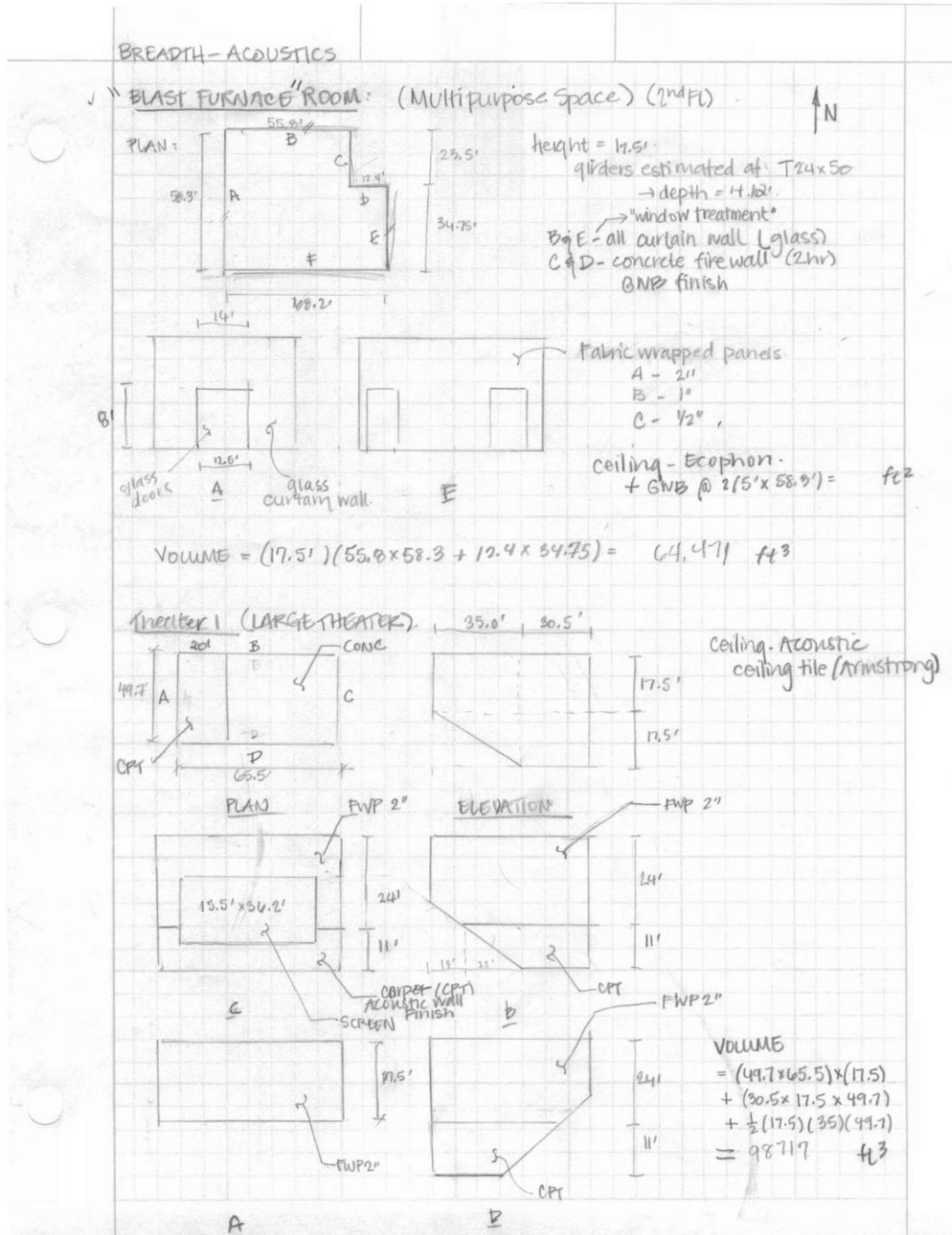

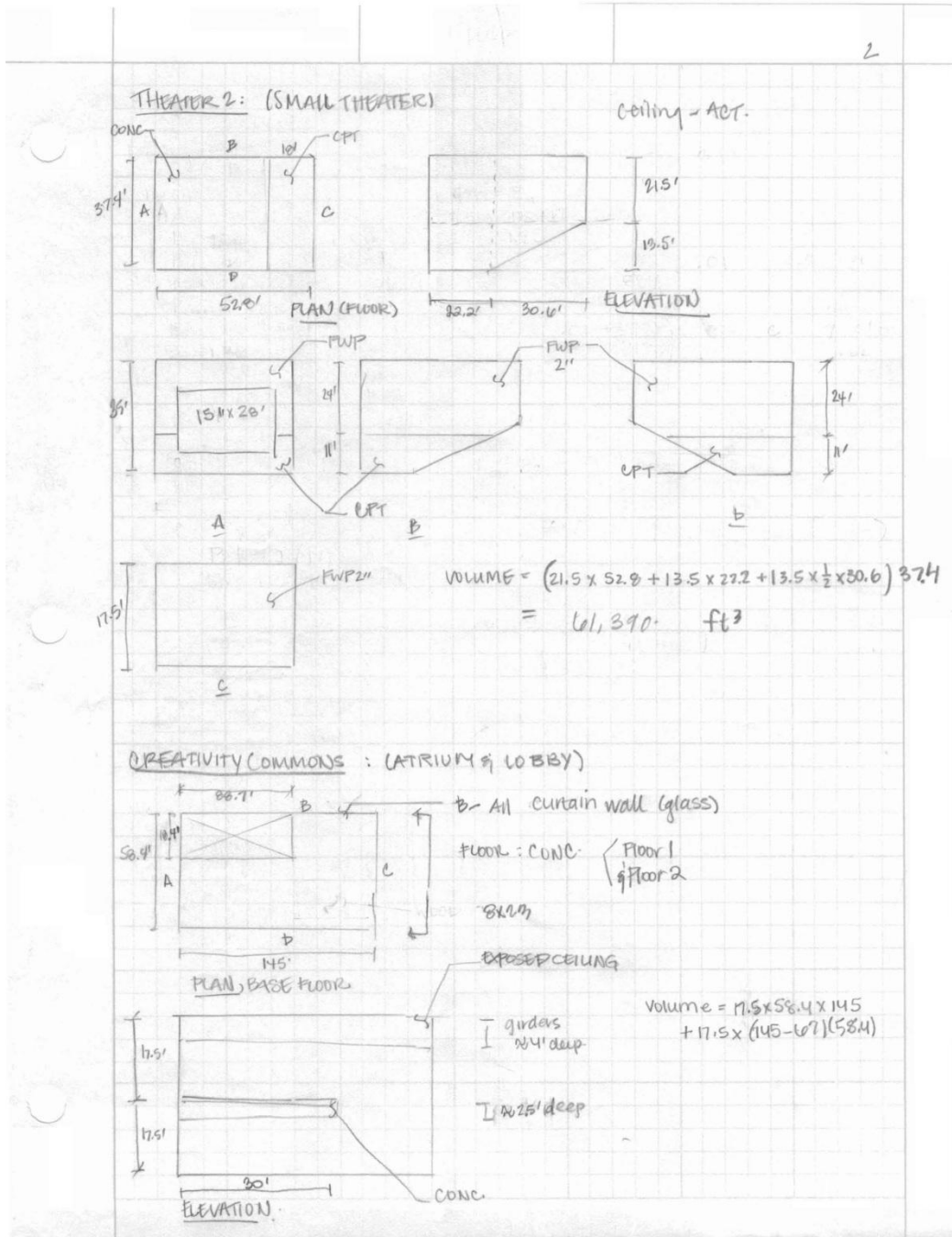

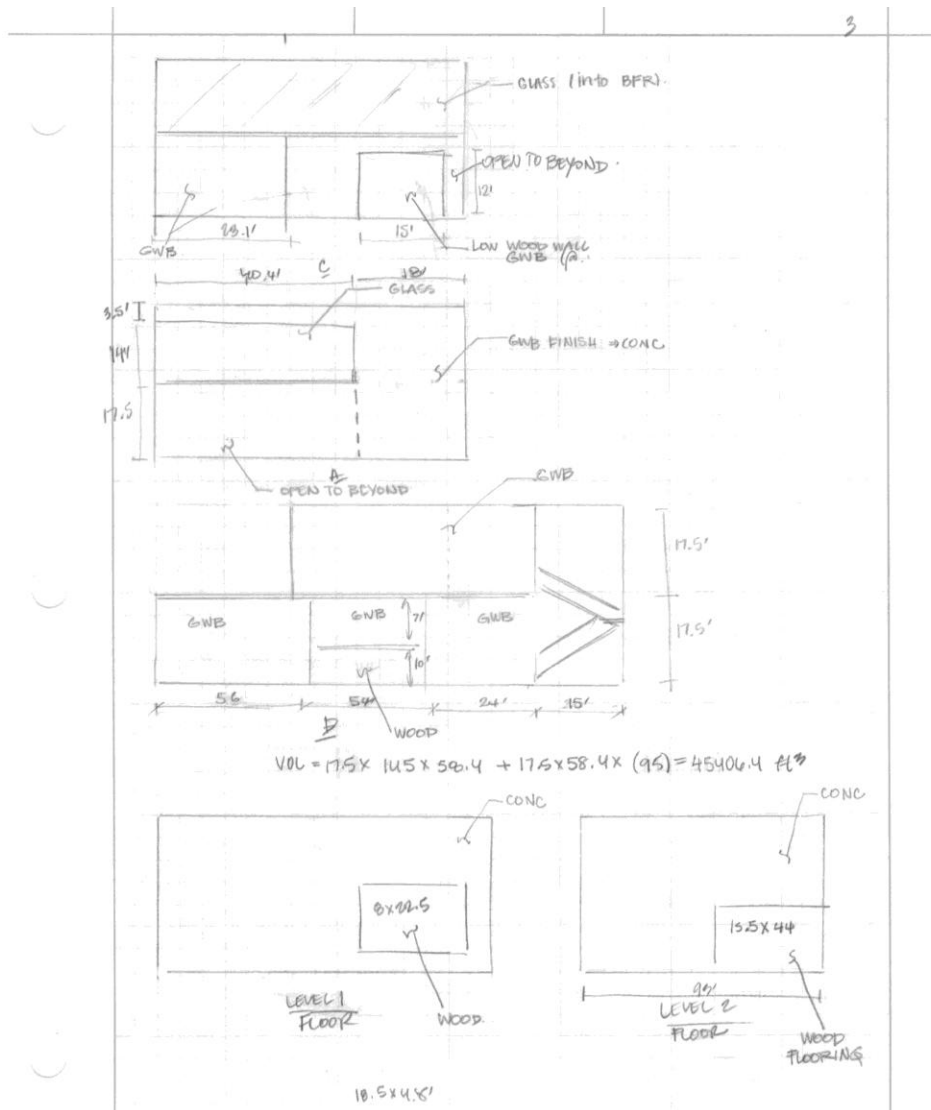

**Reverberation Time Calculator**



Volume (ft<sup>3</sup>) V = 64471.00

Total Surface Area (ft<sup>2</sup>) S<sub>total</sub> = 11493.03

Surface Description	Surface Area S (ft <sup>2</sup> )	Material Description	Sound Absorption Coefficient (α)						S*α (sabins)					
			Frequency (Hz)						Frequency (Hz)					
			125	250	500	1000	2000	4000	125	250	500	1000	2000	4000
Wall A	1020.25	Glass curtain wall	0.35	0.25	0.18	0.12	0.07	0.04	357.09	255.06	183.65	122.43	71.42	40.81
Wall B	976.50	Glass curtain wall	0.35	0.25	0.18	0.12	0.07	0.04	341.78	244.13	175.77	117.18	68.36	39.06
Wall C	411.25	GNB - PT	0.29	0.10	0.05	0.04	0.07	0.09	119.26	41.13	20.56	16.45	28.79	37.01
Wall D	217.00	GNB - PT	0.29	0.10	0.05	0.04	0.07	0.09	62.93	21.70	10.85	8.68	15.19	19.53
Wall E	608.13	Glass curtain wall	0.35	0.25	0.18	0.12	0.07	0.04	212.84	152.03	109.46	72.98	42.57	24.33
Wall F	103.89	Acoustic paneling A - 2"	0.37	0.95	0.99	0.99	0.99	0.99	38.44	98.70	102.85	102.85	102.85	102.85
Wall F	83.00	Acoustic paneling B - 1"	0.17	0.41	0.93	0.99	0.99	0.99	14.11	34.03	77.19	82.17	82.17	82.17
Wall F	85.00	Acoustic paneling C - 1/2"	0.12	0.14	0.45	0.90	0.99	0.99	10.20	11.90	38.25	76.50	84.15	84.15
Wall F	195.30	Acoustic paneling D - Perforated Metal	0.30	0.40	0.50	0.50	0.40	0.50	58.59	78.12	97.65	97.65	78.12	78.12
Wall F	314.01	GNB - PT	0.29	0.10	0.05	0.04	0.07	0.09	91.06	31.40	15.70	12.56	21.98	28.26
Wall F	116.20	Doors	0.29	0.10	0.05	0.04	0.07	0.09	33.70	11.62	5.81	4.65	8.13	10.46
Ceiling	583.00	GNB	0.29	0.10	0.05	0.04	0.07	0.09	169.07	58.30	29.15	23.32	40.81	52.47
Ceiling	3098.25	Acoustic Ceiling paneling	0.50	0.85	0.95	0.85	0.95	0.85	1549.13	2633.51	2943.34	2633.51	2943.34	2633.51
Floor	3681.25	Carpet	0.10	0.15	0.25	0.30	0.30	0.30	368.13	552.19	920.31	1104.38	1104.38	1104.38
<b>Σ(S*α)</b>								3426.32	4223.81	4730.54	4475.30	4711.78	4337.11	
<b>Avg. α</b>								0.30	0.37	0.41	0.39	0.41	0.38	
<b>Air Attenuation, m (ft<sup>-1</sup>)</b>								0.00	0.00	1.83E-04	3.26E-04	7.86E-04	2.56E-03	
<b>Sabine Reverberation Time (s)</b>								RT =	0.92	0.75	0.66	0.69	0.64	0.63
<b>Norris-Eyring Reverberation Time (s)</b>								RT =	0.78	0.60	0.51	0.55	0.50	0.52
<b>Calculated Reverberation Time (s)</b>								RT =	0.78	0.60	0.51	0.55	0.50	0.52

## Sound Transmission Criteria

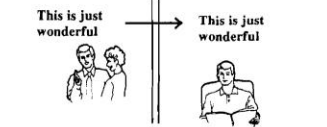
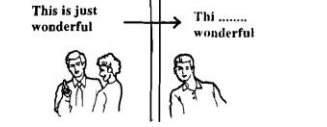
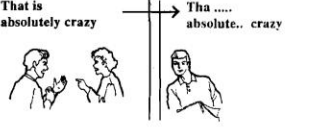
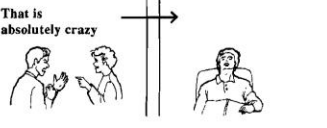
Table 6.1 Subjective Perception of STC Values\*

STC	FSTC	Subjective description
30	22 - 25	 <p>Most sentences clearly understood.</p>
40	32 - 35	 <p>Speech can be heard with some effort. Individual words and occasional phrases heard.</p>
50	42 - 45	 <p>Loud speech can be heard with some effort. Music easily heard.</p>
60	52 - 55	 <p>Loud speech essentially inaudible. Music heard faintly; bass note disturbing.</p>
70	62 - 65	 <p>Loud music heard faintly, which could be a problem if the adjoining space is highly sensitive to sound intrusion, such as a recording studio, concert hall, etc.</p>
75 and above		 <p>Most noises effectively blocked.</p>

\* This table assumes a reasonably quiet background noise level in the receiving room — NC 35 or less. See Chapter 8 for NC values.



### Cost Comparison

Label	Material	Crew	Output	Labor-hrs	unit	Material	Labor	Equipment	Total	Unit	Into S.F.	Total Cost per S.F.
1) EXISTING	300 4000 psi concrete slab				CY	102			102	8" x1x1'	0.02	2.52
	5300 metal decking, 20 ga	E-4	3600	0.006	S.F.	2.01	0.45	0.04	2.5	1	1.00	2.50
	1550 6-10" thick, pumped	c-7	110	0.655	CY		25.5	10.95	36.45	8"x1x1'	0.02	0.90
	1102 W12x16	e-2	880	0.064	L.F.	23	3.12	1.73	27.85	1	0.14	3.98
	Welded shear connectors 3/4" diameters				S.F.	0.12	0.16		0.26	1	1.00	0.26
<b>10.16</b>												
3) REDESIGN	6" conc slab				CY	102			102	6"	0.02	1.89
	1550 6-10" thick, pumped	c-7	110	0.655	CY		25.5	10.95	36.45		0.02	0.90
	650 formwork 4 use, girders & beams	c-2	310	0.155	SFCA	0.97	6.75		7.72	336 in2	0.19	1.50
	2250 forms in place, elevated slabs	c-2	480	0.1	S.F.	2.22	4.37		6.59	1	1.00	6.59
<b>10.88</b>												
2) EXISTING	conc slab				CY	102			102	8"	0.02	2.52
	5300 metal decking, 20 ga	E-4	3600	0.006	S.F.	2.01	0.45	0.04	2.5		1.00	2.50
	500 1" deflection spring isolators				EA.	34			34		0.06	2.13
	2100 r-11 batt insulation	1 carp	700	0.011	S.F.	0.38	0.51		0.89		1.00	0.89
	3000 1 layer 5/8" gypsum board	2 carp	1800	0.009	S.F.	0.27	0.4		0.67		1.00	0.67
	3000 1 layer 5/8" gypsum board	2 carp	1800	0.009	S.F.	0.27	0.4		0.67		1.00	0.67
	3000 +1 layer 5/8" gypsum board	2 carp	1800	0.009	S.F.	0.27	0.4		0.67		1.00	0.67
	1550 6-10" thick, pumped	c-7	110	0.655	CY		25.5	10.95	36.45	8"	0.02	0.90
	1102 W12x16	e-2	880	0.064	L.F.	23	3.12	1.73	27.85	1	0.14	3.98
	Welded shear connectors 3/4" diameters				S.F.	0.12	0.16		0.26		1.00	0.26
	<b>15.18</b>											
4) REDESIGN	80 3/8" plywood	2 carp	1860	0.009	S.F.	0.81	0.39		1.2		1.00	1.20
	3000 1 layer 5/8" gypsum board	2 carp	1800	0.009	S.F.	0.27	0.4		0.67		1.00	0.67
	3000 1 layer 5/8" gypsum board	2 carp	1800	0.009	S.F.	0.27	0.4		0.67		1.00	0.67
	3/4" plywood	2 carp	1300	0.012	S.F. Flr	1.24	0.55		1.79		1.00	1.79
	6" conc				CY	102			102	6"	0.02	1.89
	1550 6-10" thick, pumped	c-7	110	0.655	CY		25.5	10.95	36.45	6"	0.02	0.90
	650 formwork 4 use, girders & beams	c-2	310	0.155	SFCA	0.97	6.75		7.72	336	0.19	1.50
2250 forms in place, elevated slabs	c-2	480	0.1	S.F.	2.22	4.37		6.59	1	1.00	6.59	
<b>15.21</b>												